

BLATA

ULTIMA

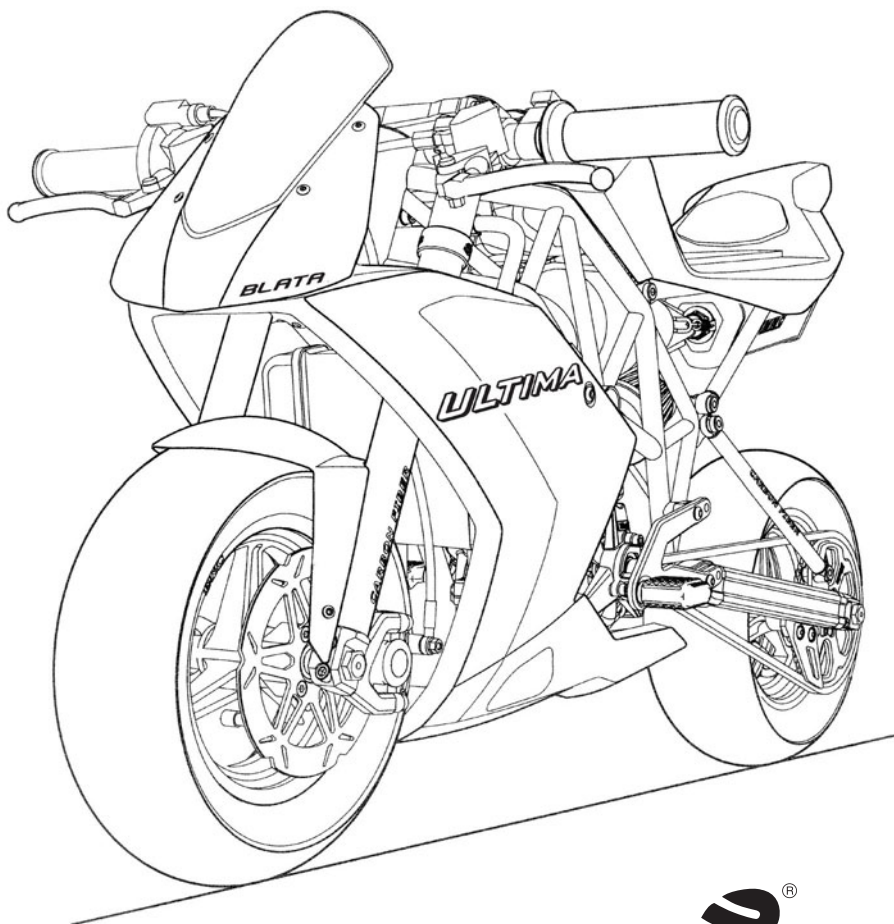

User manual for the minibike Blata Ultima EN
ver. 02-2009/12/11

Blata
www.BLATA.com



ES Declaration of conformity

Us: Blata, s r.o. Pražská 9, 678 01 Blansko
IČO 25522132

Name: Minibike
Type: Minibike Ultima Mini
Minibike Ultima Midi

Year of manufacture: 2009
Manufacturer: Blata, s r.o. Pražská 9, 678 01 Blansko

Description and purpose of use:

The Minibike – Ultima Mini and Midi are designated for riding on enclosed tracks with a flat and dust free surface. Its construction enables the riding by adults and also by children under supervision. It is equipped with a single cylinder two-stroke gasoline engine. The transfer of the driving torque from the motor to the rear drive wheel is done by a chain drive. Both wheels are equipped with disc brakes.

Relevant government orders (GO):

GO no. 24/2003 Coll. (Guideline 98/37/EC in the wording of the guideline 98/79/EC) by which are stipulated the technical requirements for machinery

GO no. 616/2006 Coll. (Guideline 2004/108/ES) by which are stipulated the technical requirements for products with regards to their electromagnetic compatibility

Applied harmonized standards, national standards and technical specifications:

ČSN EN ISO 12100-1:2004 (EN ISO 12100-1:2003), ČSN EN ISO 12100-2:2004 (EN ISO 12100-2:2003), ČSN EN ISO 13857:2008 (EN ISO 13857:2008), ČSN EN 953:1998 (EN 953:1997), ČSN EN ISO 13732-1:2007 (EN ISO 13732-1:2006), ČSN EN ISO 14121-1:2008 (EN ISO 14121-1:2007), Předpis EHK č. 010 (72/245 EHS).

10.07.2009

Place of issue, date

CFO

Name and function of responsible person

Signature

SAFETY WARNING



Pay extra attention when performing maintenance and service of the machine and maintain the safety warning and instructions stated below!

Before putting the minibike into operation, familiarize yourself carefully with instructions about its proper use and maintain them in the interest of your safety and also the safety of others. The manufacturer and distributor are not responsible for damages, or eventual injuries caused by procedures which are contrary to the manual and the safety instructions.



This vehicle is not designated for operation on public communications!



Serious injury can occur during careless manipulation with this machine. The rider can decrease these eventual risks to a minimum by using safety equipment. The rider must properly use the safety helmet, eye protection, protective gloves, elbow and knee protectors and suitable footwear. Avoid uneven surfaces and obstacles. Hold the handlebars with both hands while driving. Have both feet placed on the foot pegs.



Perform the prescribed inspection of the vehicle before each ride, see "Regular maintenance". The nonperforming of the prescribed regular inspections and maintenance increases the risk of an accident and damage to the vehicle.



The fuel and its fumes are highly toxic and flammable. Careless manipulation with the fuel can result in burns or poisoning. Therefore:

- while filling up the fuel always turn the engine off and keep away from open flame and sparks; don't smoke
- only fill up the fuel while outside or in proper ventilated areas
- immediately wipe off spilled fuel
- make sure that children and animals are kept at a safe distance



Do not overestimate your capabilities or the capabilities of the machine while riding. Adjust the riding to the conditions on the riding track. In this way you will avoid unnecessary injuries and damage to the machine.



Serious injury can occur while performing maintenance, with the engine running, by the hands or parts of the clothing being caught into the moving parts. Always turn the engine off and let it cool down before performing inspections or maintenance.



It is necessary to let the hot parts of the engine and exhaust cool down before performing any manipulation in that area, such as for example the replacement or cleaning of the spark plug, the lubricating or tightening of the chain.



The incorrect adjustment of the chain and the use of a chain that is in a bad technical state increases the risk of an accident, therefore perform an inspection and an adjustment of the chain before every ride.



Neglect of inspection and maintenance increases the risk of an accident during riding. Before every ride inspect the brake cable / lines and the effectiveness of the brake.



The bad condition of the brake pads can be a cause of decreased effectiveness of the brake and can therefore be a cause of an accident during riding. Therefore inspect and replace the brake pads according to the instructions of this manual.



The use of worn and incorrectly inflated tires, or tires that are of incorrect size, decreases stability and can cause an accident.



Brake fluid causes damage to skin and eyes. When working with the brake fluid always use protective gloves and protect the eyes by using safety glasses.

PACKAGE CONTENT

The complete delivery of the minibike Blata Ultima is composed of:

- Transport packing - carton box
- Minibike
- User manual
- Stand
- Document of payment
- The packing can optionally contain further additional or spare parts which were ordered together with the minibike

During unpacking it is necessary to follow the instructions stated in the chapter Preparation of the minibike for operation. Immediately report to the transport company any visible damage to the delivery. Check the package content with the order and immediately report any defects to the seller, eventually to the manufacture. That is not possible to acknowledge a claim made later.

GENERAL WARNING

- The manufacturer is presenting the user manual with the purpose of providing the user with all the necessary information and instructions for the effective use of the machine.
- The user manual was elaborated by the manufacturer and makes up an inseparable part of the machine's accessories. The information contained in the user manual is designated for qualified workers.
- The use of this manual is in the full responsibility of the user. It is necessary to consider all the operations, which are not described here, as being forbidden. The service worker performing such operations will carry all the responsibility for the results of his actions. It is necessary for the user manual to be stored for possible future references.
- The actual version of the manual, corresponding to your minibike, is identified on the front page of the manual.
- The responsibility of the user (operator) and the service personnel is to properly familiarize themselves with this manual before they begin using the equipment. This will eliminate mistakes which could occur during its installing and also during its use. Therefore do not attempt to bring the equipment into operation prior to properly studying this manual.
- The manual contains everything that is necessary to know for the correct setting up and operation of the machine. You will prevent losses and will be satisfied with the functionality of the machine and its long service life if you maintain all the instructions in the manual.
- The manual also contains important information about work safety, assembly, operation and maintenance and it is necessary to consider it as a part of the equipment. The failure-free and safe work with the equipment and its service life significantly depends on its correct and thorough maintenance.
- The operator of the equipment must be familiarized with its functions and controls and must be instructed about safety.
- Follow the safety instructions during work in order to avoid the danger of the injury of yours or persons nearby.
- The manufacturer is not responsible for the damages caused by procedures which are contrary to this manual and safety instructions.
- Please read this user manual carefully before transporting the machine, putting it

- into operation, using it, performing maintenance or performing any other intervention. Make sure that it is stored near the machine so it is constantly available.
- Do not, under any circumstances, use the machine in any other way than is described in this manual. The manufacturer does not take over any responsibility for damages caused to property or the health of persons, which are the result of not following the safety regulations.
- Use all the necessary protective means such as clothing, protective gloves and safety glasses.
- Do not allow unauthorized persons to perform repairs, maintenance or other activities of any type on the machine.
- Transportation and activities related with the installing and assembly should be performed only by persons which have the necessary technical competence.
- All works on the electrical system should only be performed by competent persons.
- Always first turn off the engine and shut off the fuel supply during any type of a malfunction, cleaning etc.
- It is necessary to bring attention to the danger resulting from certain types of clothing, such as sleeves which can be caught into objects that may cause injury to the operator, if they are wearing it during work. Due to this reason it is desirable for the operator of the machine to not use dangerous objects such as, for example: rings, a watch, bracelets, clothing with wide sleeves, loose belts, ties and generally any clothing which can loosely hang and which can be caught by the movable parts of the machine. Persons with long hair must have it tied up, eventually hidden under the helmet.

FORBIDDEN USE

The following activities are not allowed:

- The use of the machine without the protective elements or the removal of these protective elements.
- The use of the machine without safety equipment, as it is described in the safety warnings.
- It is forbidden to perform any modifications to the machine.
- Other use than that which is described in the user manual.
- Allowing children and other unauthorized persons access to the machine.
- Using any other spare parts than original spare parts.
- Rough handling of the machine, mainly its overloading, dangerous riding, riding on an unsuitable surface etc.
- Endangering other persons and animals during riding.
- Using the machine when it is damaged or improperly set up.
- Using the machine when under the influence of alcohol or other narcotic and psychotropic substances.
- Using the machine by injured, physically or psychologically incompetent persons.



All damages to health and property, which are the result of incorrect use of the machine, will be the sole responsibility of the user.

CONTENT

Introduction	2
Technical data	3 - 4
Preparation of the minibike for operation	5
Safety warning	5
Before starting	5
Important warning	6
Starting	6
Riding	6
Regular maintenance	7
Maintenance and adjustment of the chain	7
Adjustment of engine bottom bracket	8
Bleeding the hydraulic brakes	9
Replacement of the brake pads of the hydraulic brakes	11
Adjustment of the mechanical brakes	11
Replacement of the front brake pads of the mechanical brakes	12
Replacement of the rear brake pads of the mechanical brakes	12
Removal and mounting of the front wheel	13
Removal and mounting of the rear wheel	14
Replacement of the pinion	14
Change of the geometry of the chassis	15
- change of the steering angle	15
- change of the seat height	17
- change of the foot pegs position	18
Replacement of the centrifugal clutch levers	19
Replacement of the tire	19
Removal and mounting of the air filter	19
Adjustment of the centrifugal clutch	20
Maintenance of the cooling system	21
Tightening torques	22
Composite materials	23
Noise	24
Declaration about noise	24
Putting out of operation	25
Storage	25
Repeat putting into operation	25
Permanent putting out of operation	25
Technical service	25

CONTENT - SPARE PARTS

Hydraulic brakes	27
Hose	27
Hydraulic brake lever	28
Hydraulic brake caliper	28
Mechanical front brake	29
Mechanical rear brake	29
Mechanical brakes holder	30
Engine - complete	30
Engine R40, RM9, RM14	31 - 32
Engine W40	33 - 34
Engine W50	35 - 36
Rotor	37
Starter case - complete	37
Clutch case - complete	38
Clutch - complete	38
Diaphragm - complete	39
Exhaust R40 (RM9, RM14)	39
Head blast - water, air cooling	40
Front fork	41
Front wheel	42
Rear wheel	42
Frame	43
Tank - complete	44
Radiator	44
Exhaust - complete W40	45
Exhaust - complete W50	45
Exhaust silencer	46
Cowling	47 - 48
Cowling table	49 - 50
Identification information	51

INTRODUCTION

The Minibike - Ultima is designated for driving on enclosed tracks on flat and dust free surfaces. Adults and also children can ride on it. Children can only ride on it under the supervision of a responsible adult. With its construction and equipment the minibike is designated mainly for races on special tracks. The minibikes Blata are not designated to be used during winter and under worsened climatic conditions. When the minibikes Blata are used during winter and during worsened climatic conditions there occurs an increase of the mechanical wear and tear of most of the product's parts and corrosion of these parts, especially of the groups that are exposed to the direct acting of the external effects. Besides this, the driver exposes themselves to the danger of injury or permanent damage to health, especially while riding under worsened climatic conditions and mainly during winter.

The minibike is equipped with a single cylinder two-stroke gasoline engine, which is fitted with an air filter and an exhaust with a damper. The transfer of the driving torque from the motor to the driven rear wheel is done by a chain drive, whose ratio can be modified in small limits by the replacement of the sprocket wheels. Both of the minibike's wheels are fitted with disc brakes. The rear brake is controlled by a lever on the left side and the front brake is controlled by a lever on the right side of the handlebars.

TECHNICAL DATA

engine (Blata 2T)	RM9	RM14	R40	W40	W50
cooling	air	air	air	water	water
displacement (cm ³)	39,8	39,8	39,8	39,8	49,7
power (kW)	3,3	5,9	7,5	10,7	12
torque (Nm)	3,5	4,8	7,2	8,6	10,7
carburetor	DELL'ORTO PHVA 14	DELL'ORTO PHVA 14	DELL'ORTO PHVA 14	DELL'ORTO PHVB 19	DELL'ORTO PHVB 19
ignition	contactless	contactless	contactless	contactless	contactless
starting	manual	manual	manual	manual	manual
clutch	automatic centrifugal	automatic centrifugal	automatic centrifugal	automatic centrifugal	automatic centrifugal
frame	steel tube frame, rear fork is made of dural (*), under seat frame is made of dural (*), front fork is steel or dural-composite				
front brake	disk, hydraulic or mechanical				
rear brake	disk, hydraulic or mechanical				
front wheel	dural 2,1" x 6,5" - 99				
rear wheel	dural 2,3" x 6,5" - 130				
front tire	90 / 65 - 6,5"				
rear tire	110 / 50 - 6,5" or 90 / 65 - 6,5"				
fuel	33 : 1 (gasoline 95 - 98 octane: 2T synthetic oil)				
fuel tank volume	1,4 litres				
weight	18 - 20 kg (in relation to equipment)				
carrying capacity	max 100 kg				
dimensions L x W x H (mm)	MINI 915 x 550 x 525, MIDI 995 x 550 x 550				

* optional with composite elements

PREPARATION OF THE MINIBIKE FOR OPERATION

The Minibike is delivered packaged in a carton box with folded handlebars and brake levers. After unpacking, set the handlebars to the functioning position which suits you best. When turning all the way the brake levers must not come into contact with the fairing. After setting it up tighten the screws of the handle bar clamps (1), the brake lever screws (2) and the throttle handle screws (3) see fig. 1. Verify the smooth and free movement of the throttle control cable and both of the brake hoses / cables.

Check that the cooling system is filled with fluid - in the leveling reservoir (7) the fluid must be up to 1 volume. In case of filling up the fluid, perform the air venting (procedure according to chap. MAINTENANCE OF THE COOLING SYSTEM). Fill the tank with fuel.

fig. 1

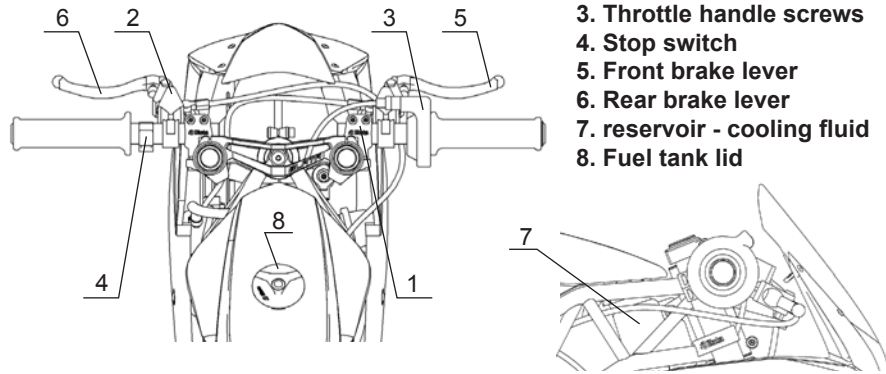

Control elements:

1. Handle bar clamp screws
2. Brake lever screws
3. Throttle handle screws
4. Stop switch
5. Front brake lever
6. Rear brake lever
7. reservoir - cooling fluid
8. Fuel tank lid

SAFETY WARNING

This vehicle does not totally conform to the regulation of the MD (Ministry of Transportation) no. 341/2002 Coll. and it is not permitted for operation on public communications. Careless operation of this machine can result in serious injuries. The rider can decrease these eventual risks to a minimum by wearing safety equipment. The safety helmet must be properly worn (covering the ears - mainly for children), eye protection, protective gloves, elbow and knee protectors and suitable footwear. Do not use this vehicle on an icy or oily surface. Avoid uneven surfaces and obstacles. Always hold the handlebars with both hands.

BEFORE STARTING

For the service life of the engine and for its power it is necessary for the minibike to be properly run in. The motorbike is considered as being run in after the consumption of a volume of five full fuel tanks. For running in use the gasoline 95 - 98 octane with synthetic oil for two-stroke motors (2T) in a ratio of 30 : 1, after the run in use a ratio of 33 : 1. Thoroughly mix the mixture of fuel and oil before pouring it into the tank! During the run in period do not spin the motor to the maximum revolutions and do not let the motor overheat. Check the tire air pressure - 200 kPa (2 bars), which can be modified according to the weight of the rider. The pressure in one tire must not exceed 250 kPa (2.5 bars) on the front and also the rear wheel.

IMPORTANT WARNING

Turn the engine off immediately if the level of the cooling fluid in the leveling reservoir increases during operation! Check the drive of the cooling pump and the cooling system for leaks. After this inspection perform an air venting. The increased level of the cooling fluid is a sign of an overheated motor and the piston can get seized in the cylinder.

STARTING

Perform the starting only up on the stand - see fig. 2. Fill the minibike tank with fuel and close it by screwing on the cap. Open the fuel supply valve. Move the choke lever from the position "A" to the position "B" fig. 3 and pull the starting cord twice without turning the throttle handle. You will start up the engine with the next quick pull. After the engine has been running for a while, move the choke lever back to the position "A". Leave the motorbike on the stand with the engine running and if it is necessary then adjust the engine revolutions to a level where the clutch does not drive the rear wheel. Perform the adjustment by the screw (3) on the carburetor fig. 3.

fig. 2

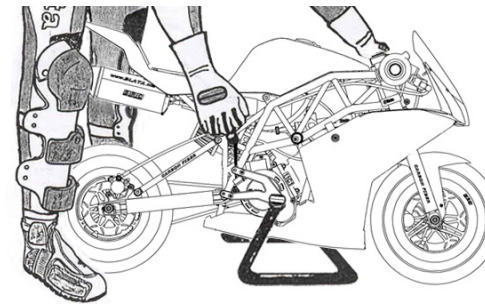

- A - Choke lever position for riding
B - Choke lever position for cold starts

fig. 3

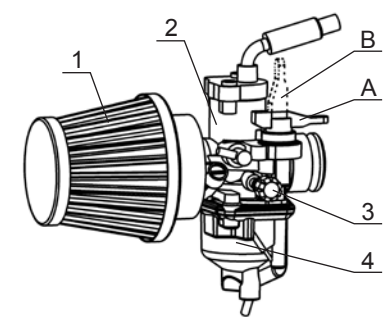

Carburetor (applies to carburetor PHVA 14, PHVB 19):

1. Air filter
2. Body of the carburetor
3. Adjustment screw for idle running
4. Float chamber

RIDING

After sitting on the minibike and turning the throttle handle we start to ride. Before braking decrease the fuel using the rotary handle and using the left-hand first lightly squeeze the rear wheel brake lever and then use the right hand to squeeze the front brake lever. During this pay attention so that the wheels do not go into a slide. The minibike engine is turned off by pressing the red button of the switch on the handlebars. AFTER THE FIRST RIDE IT IS NECESSARY TO INSPECT THE TIGHTNESS OF THE BOLTS AND NUTS, ESPECIALLY OF THE ENGINE AND THE CHASSIS PARTS. Re-inspect the effectiveness and the adjustment to the breaks.

REGULAR MAINTENANCE

Regular performing of maintenance is one of the best methods of contributing to the prolonging of the service life of the machine, ride safety and the lowering of expenses.

A - Before each ride:

- Inspect the cables / hoses and the effectiveness of the breaks.
- Inspect the lubrication and the adjustment of the chain drive. The chain should have a slack of 5 mm.
- Always clean the minibike and maintain it in a clean state after every use. Do not use aggressive cleaning products.
- After 1 hour of riding always wash the air filter in gasoline and smear oil on to it for air filters. The same applies after every ride in the rain.
- After 1 hour of riding clean the clutch with compressed air and perform an inspection of the adjustment of the clutch levers.
- Inspect the condition of the brakepads. The lining thickness cannot be less than 1 mm. Perform the basic adjustment of the brakes.
- Inspect the cooling system for leaks and the amount of the cooling liquid in the leveling reservoir - must be 1/2 the volume of the reservoir.
- Inspect the condition of the clutch lining - its thickness cannot be less than 1 mm! Perform an adjustment of the clutch levers.
- Make a visual inspection of the entire minibike. Replace all the damaged parts (worn, deformed) with new ones.
- Inspect the tires' air pressure.
- Inspect the tightness of all the bolts and nuts - see the tightening torques table.

B - Always following 5 hours of operation:

- Thoroughly clean the float chamber of the carburetor.

MAINTENANCE AND ADJUSTMENT OF THE CHAIN

Loosen the rear wheel axle and the check nuts of the adjustment bolts. Adjust the recommended slack of the chain to 5 mm, by even tightening / loosening of the adjustment bolts on both sides. Tighten the wheel axle. Tighten the check nuts of the adjustment bolts against the movable blocks. It is suitable to measure the given measurement (x) using a slide gauge (it must be the same on both sides of the fork).

The chain must be regularly lubricated which increases its service life and decreases the operational noise. The chain must be lubricated every time after riding on a wet road. We recommend to lubricate it with a special oil in a spray. If it is necessary to replace the chain then also inspect both of the sprocket-wheels. If they are worn then they must be replaced with the chain at the same time.

fig. 4

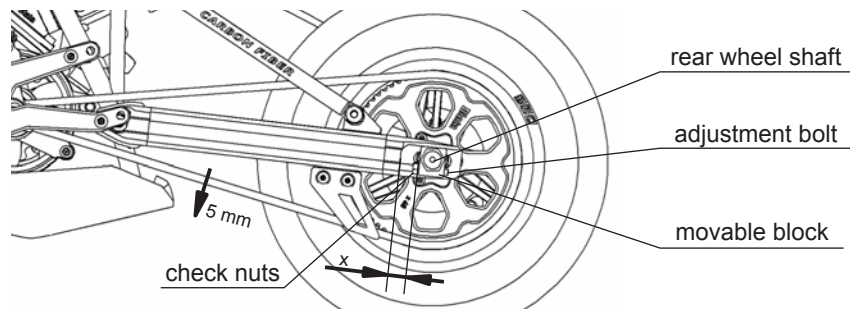

SEŘÍZENÍ SPODNIHO DRŽÁKU MOTORU

1. Remove the engine bracket on cylinder head and keep the engine on the bottom bracket only.
2. Loosen the screw M8x120 in the engine bottom bracket (keep screwed).

fig. 5

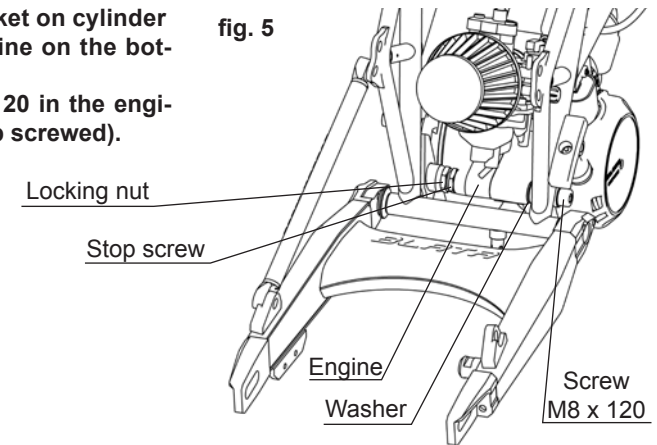

3. Turn the engine in the bottom bracket utmost down. Herewith you will make space for work with spanners, fig. 6. Loosen the lock nut and stop screw.

fig. 6

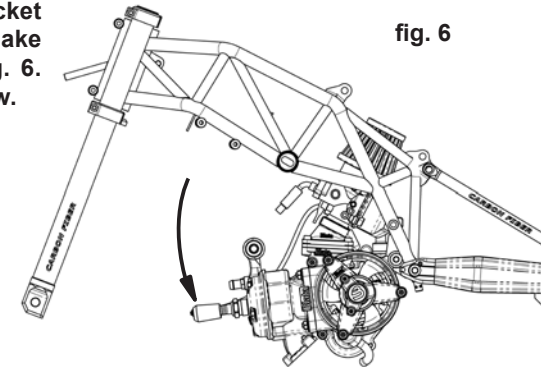

4. Using a set of keys on the bottom bracket of the engine No.: 269.440.00 torque first stop screw against the engine and then tighten the lock nut to lock against the eye frames, fig. 7.
5. Turn the engine back to its original position and mount bracket to cylinder head.
6. Tighten the screw M8x120 on the bottom engine mount.

fig. 7

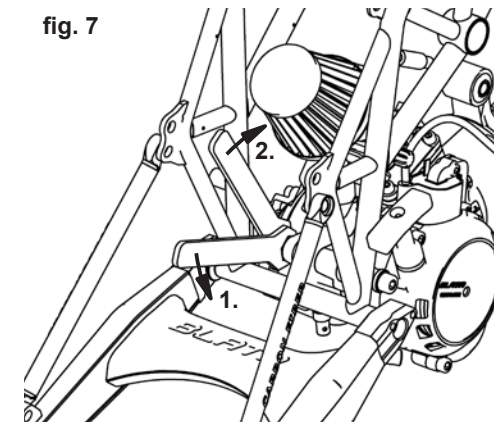

The above-described adjustment of the lower bracket of the engine perform at each dismantling the engine or engine replacement. To ensure stop screw, locking nut and screw is recommended to use glue thread.

BLEEDING THE HYDRAULIC BRAKES

important warning:

- The brakes are one of the most important components of your minibike. We recommend to leave the maintenance and the adjustment of the hydraulic brakes up to a qualified mechanic.
- Follow the safety warning.
- Use only the brake fluid DOT4.
- When working with the brake fluid make sure to prevent it coming into contact with other parts of the brakes and other parts of the minibike. Primarily protect the brake pads and the brake discs.

For bleeding the hydraulic brakes we recommend to use the Bleeding set (or. no. 262.900.00). The procedure is the same for the front and the rear brake. Remove the hydraulic brake from the minibike. In to the caliper, between the brake pads, we insert the brake disc or a metal plate of the same thickness. Place the brake into the position as illustrated in the picture no. 8 - flow-through bolts at the caliper and also the lever are pointing upwards, the brake lever is higher than the caliper.

Brake fluid may escape in the area around the flow-through bolts. We recommend wrapping the flow-through bolts with an absorbing material before performing the bleeding. Remove the bleeder plugs (wrench TX10) from the flow-through bolts on the caliper and the lever and remove the bleeder plug O-ring seals. Place the hoses with the reduction for the M5 thread on to the sprayers from the bleeding set. Fill one sprayer with brake fluid – approx. 20 ml. Screw this sprayer into the flow-through bolt on the brake caliper. Leave the second sprayer empty and screw it into the flow-through bolt in the lever. With gentle pressure, start to push the brake fluid from the full sprayer to the empty one. The pushing through of the entire volume of 20 ml should take at least 20 seconds. Do not push out the full sprayer completely, but stop the pushing through at least 5 mm before reaching the bottom. Too quick of a pushing through of the fluid may cause damage to the parts inside the brake. After pushing through the entire volume, first unscrew the sprayer on the side of the lever and screw in the bleeder plug with the O-ring. Then unscrew the sprayer on the side of the caliper and screw in the bleeder plug with the O-ring. Clean any spilled brake fluid off of the brakes and mount them back on the minibike. Verify the proper function of the brakes before riding.

fig. 8

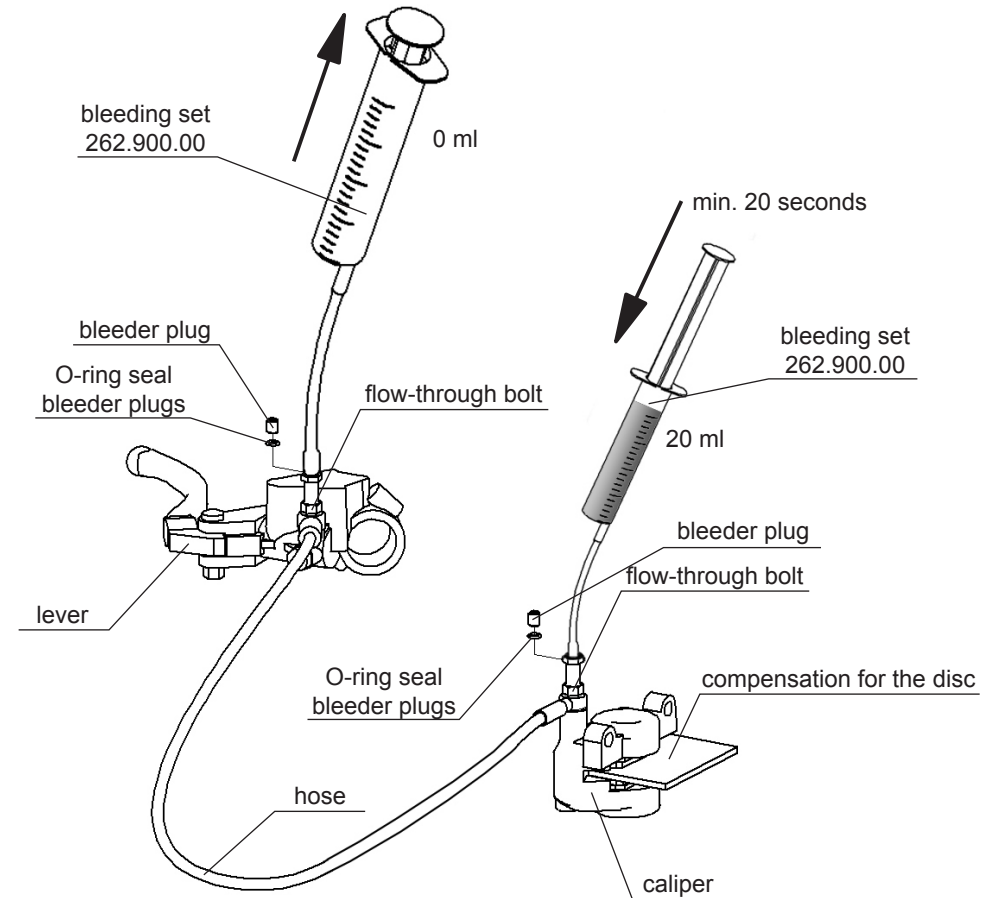

REPLACEMENT OF THE BRAKE PADS OF THE HYDRAULIC BRAKES

Loosen the lock ring of the bolt of the brake pads. Unscrew the bolt of the brake pads. Remove the worn pads from the caliper together with the metal spring of the brake pads. Place the metal spring between the pair of new pads and place the set into the caliper. The tongues on the brake pads must fit into the shape in the brake caliper. Screw in the bolt for the brake pads (must pass through the openings in the brake pads) and secure it with the lock ring.

fig. 9

rear brake

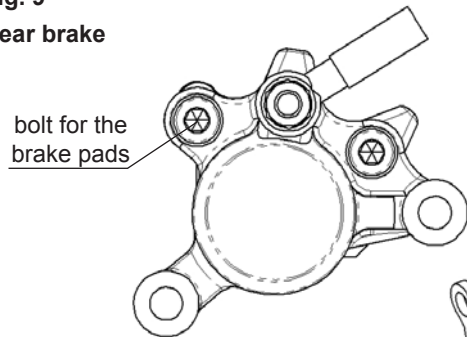
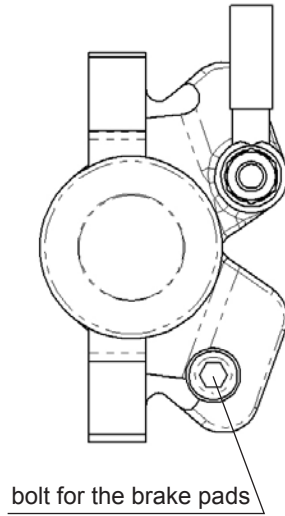

fig. 10

front brake



metal spring
for brake pads

bolt for the brake pads

ADJUSTMENT OF THE MECHANICAL BRAKES

General adjustment:

The general adjustment of the mechanical brakes is performed by the adjustment mechanism of the brake levers on the handlebars.

Basic adjustment of the mechanical brakes:

Put the adjustment mechanism on the brake lever to the initial position. Loosen the nut (1) and screw in the adjustment bolt (2) so that the wheel does not turn. Return the bolt (2) back by 1/4 to 1/2 a turn and tighten the locking nut (1). *Do not use the cable catch (3) for adjusting the brakes!*

fig. 11

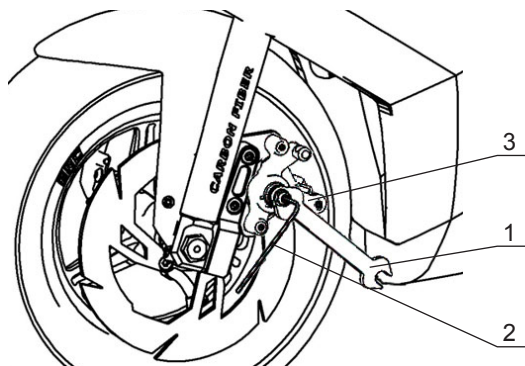

REPLACEMENT OF THE FRONT BRAKE PADS OF THE MECHANICAL BRAKES, fig. 30

First screw in the adjustment mechanism of the right brake lever (122.002.00) to the initial position on the handlebars. Loosen the nut (332.020.00) and unscrew the adjustment bolt (916.065.02) so that during the squeezing of the front brake lever the cam lever (312.017.00) is above the head of the bolt M5 (312.018.00), which secures the brake pads and the pads spring (312.020.00). Unscrew this bolt and replace the worn brake pads with new ones. During assembly, carefully place the pads spring, so that both of the pads are pushed in the direction towards the front stop. During the replacement of the pads do not loosen the bolts M5 (914.001.01) on the guide pins and do not loosen the cable catch!

REPLACEMENT OF THE REAR BRAKE PADS OF THE MECHANICAL BRAKES, fig. 31

First screw in the adjustment mechanism of the left brake lever (122.001.00) to the initial position on the handlebars. Loosen the nut (332.020.00) and unscrew the adjustment bolt (916.065.02) all the way to the end. Unscrew the nut M10 (920.011.01) of the rear axle, slide it out and remove the rear wheel from the fork. Slide the brake off of the guide pins, which releases the brake pads, and replace them with new ones. During the replacement of the pads do not loosen the bolts M5 (914.001.01) on the guide pins and do not loosen the cable catch! During assembly proceed in the reverse manner and then perform the adjustment and the basic adjustment of the brake.

REMOVAL AND MOUNTING OF THE FRONT WHEEL

Unscrew the nut of the front wheel axle and slide the axle out. Remove the wheel carefully from the fork in the downward and forward direction. During assembly it is necessary to pay attention to the correct placement of the spacers between the wheel and the end piece of the front fork. The length of the spacer is different for the right and the left side.

fig. 12

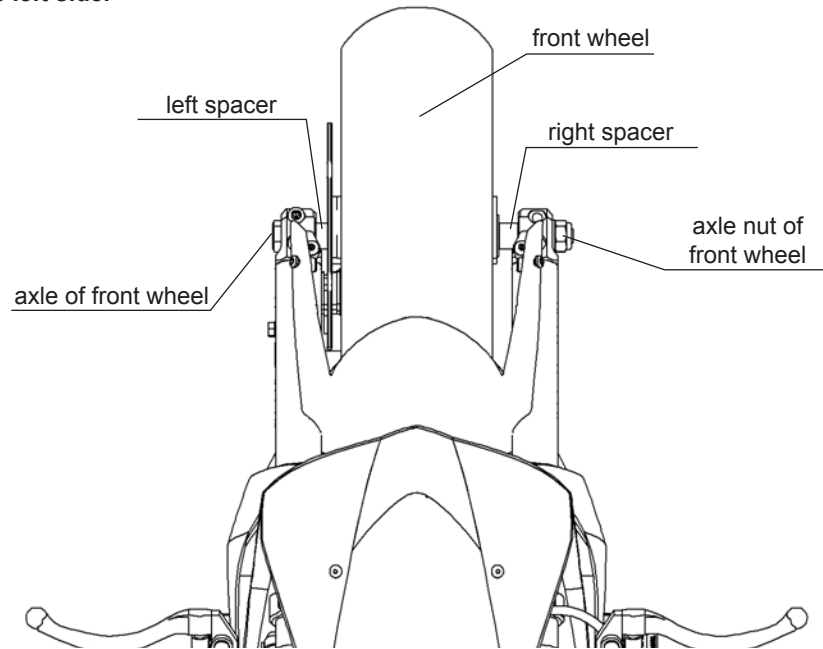

REMOVAL AND MOUNTING OF THE REAR WHEEL

Loosen the nut of the rear wheel axle. Loosen the check nuts and the adjustment bolts on the movable blocks. Move the wheel forward in the rear fork end piece and remove the chain off of the sprocket. Slide out the rear wheel axle and carefully remove the rear brake caliper from the disc. When mounting the rear wheel back it is necessary to pay attention to the correct placement of the spacers. The spacers are different for the right and the left side. Place the rear brake caliper holder on to the right spacer and continue in the reverse procedure. After the mounting of the rear wheel perform an adjustment of the chain.

fig. 13

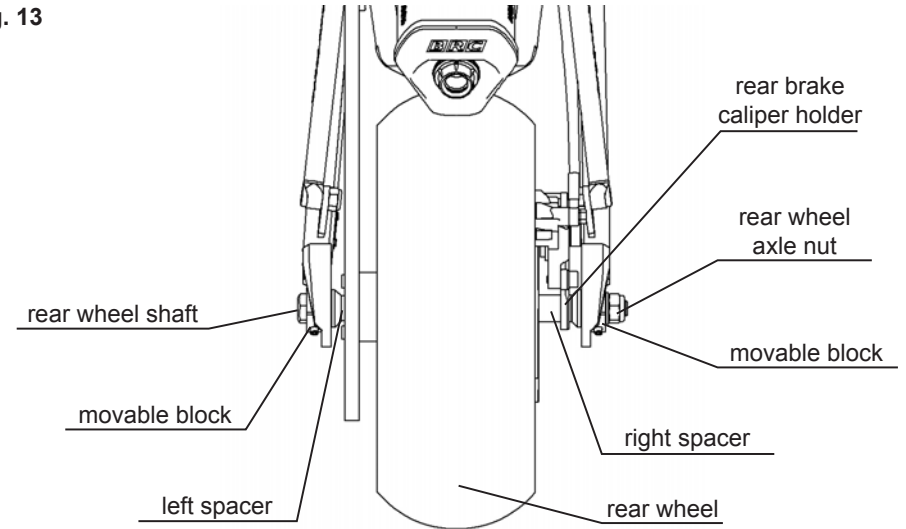

REPLACEMENT OF THE PINION

First remove the bearing housing on the left side of the motor. Loosen the nut of the rear wheel axle and the chain tensioner bolts and take the chain off of the pinion. Carefully slide a steel rod or a screwdriver into the opening of the clutch drum fig. 14, so that the clutch drum is prevented from turning during the loosening of the pinion. Use a special wrench (319.050.00) to loosen the pinion by turning counterclockwise. The assembly of the new pinion is performed in the reverse procedure.

fig. 14

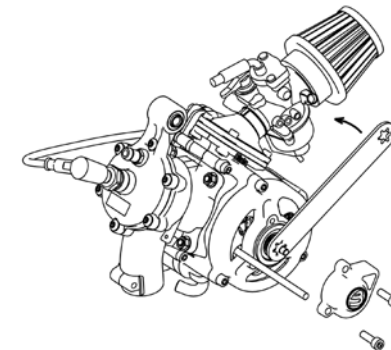

CHANGE OF THE GEOMETRY OF THE CHASSIS

The BLATA SET-UP SYSTEM includes three areas of the minibike, in which it is possible to significantly change the geometry of the chassis. This is the change of the steering angle using exchangeable steering plates, the change of the seat height using adjustable rear fork supports and the change of the foot rests' position.

Suitable adjustment of the geometry of the chassis, according to the demands of the rider and the track characteristics, significantly improves the control of the minibike and moves the limits of possibilities during the ride. Following any modification to the geometry of the chassis pay extra attention during the first ride, because the minibike will act in a different manner than what you're used to.

fig. 15

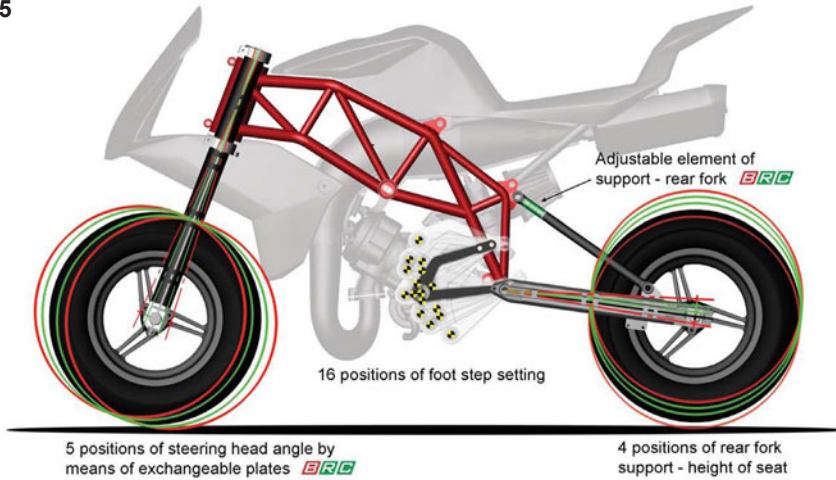

Change of the steering angle

The change is possible by exchangeable steering plates, which enable to change the steering angle by values of $\pm 2^\circ$ to $\pm 4^\circ$.

Perform the replacement of the plates in the following manner with the cowling removed. Remove the steering shock absorber bolt on the bottom holder of the front fork. Loosen the steering axle nut under the bottom fork holder. Slide out the steering axle. Remove the entire loosened front fork set from the steering neck in the forward direction (we recommend to have another person assisting, which will be holding this set during the course of the next steps). Loosen the bolts in the clamps on the steering neck. Slide a rod with a diameter of 6 mm through the steering neck and carefully knock out one plate with the bearing. Remove the spacer tube and knock out the second plate from the other side.

important warning:

- Always mount the steering plates on to the minibike in a pair with the same angle difference (same color).
- Always position the steering plates so that the groove in the steering plate lies on the groove in the steering neck on the frame fig. 17.
- The plates in the steering neck must always be positioned against each other (for example the top plate with bearing in front, the bottom plate with bearing in the rear) fig. 18.

Carefully tap in the required steering plate into one end of the steering neck. Insert the spacer tube and tap in the second plate from the other side of the steering neck. Pay attention to the proper positioning of the plates, as it is described above. Place the front fork set onto the steering neck. Insert spacers between the upper holder of the fork and the upper plate and between the lower holder of the fork and the lower plate. Draw the set together with the steering axle and tighten the bolts in the clamps on the steering neck. Attach the steering shock absorber to the bottom holder of the fork.

fig. 16

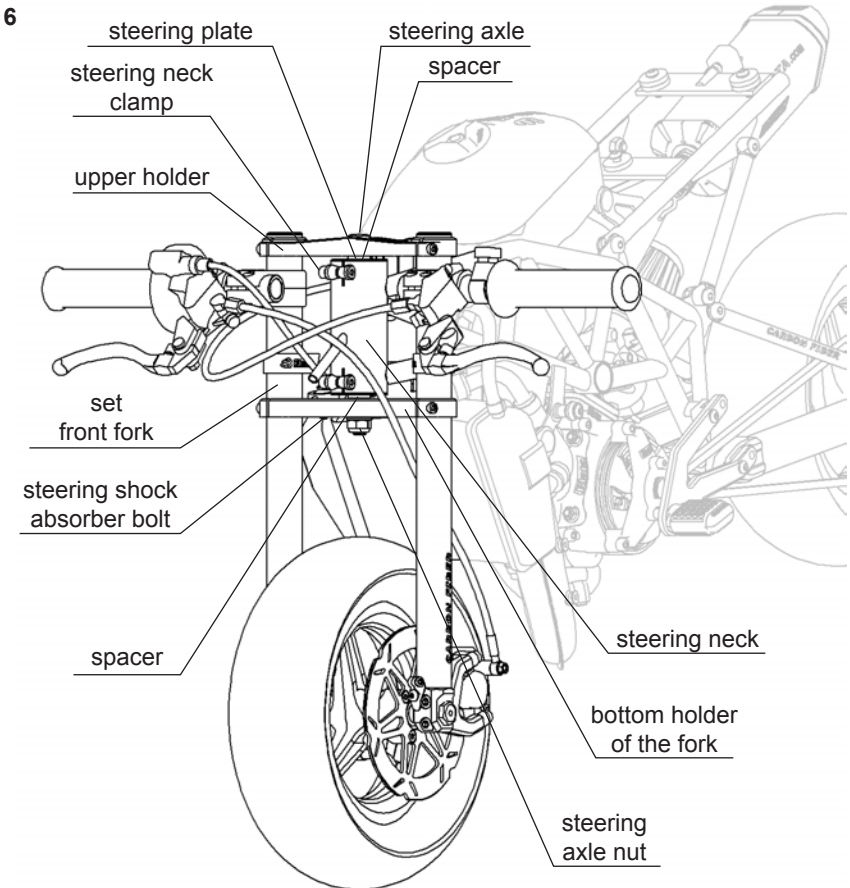

fig. 17
proper setting of the steering plate
in the steering neck

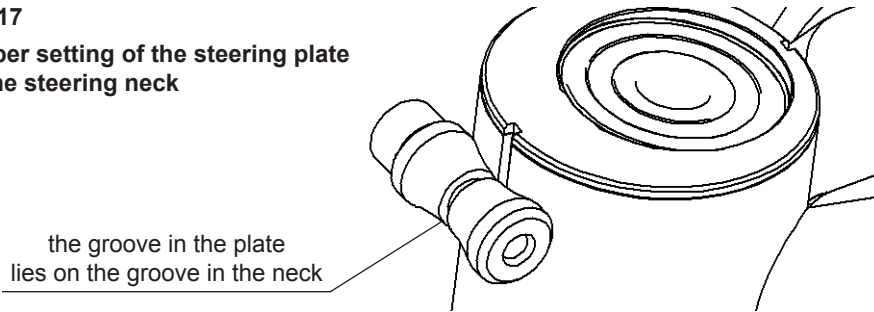
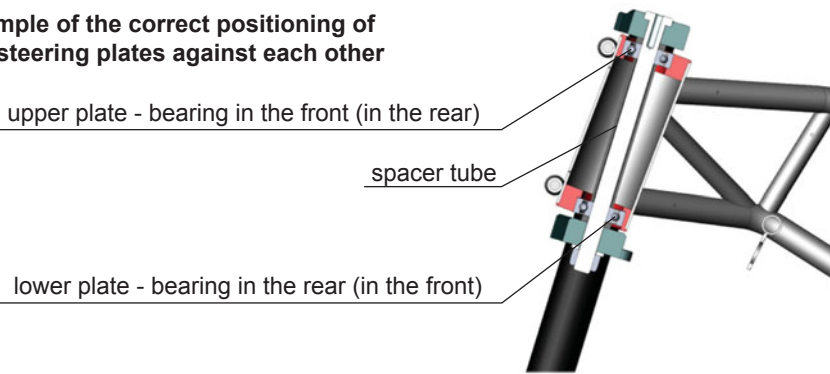
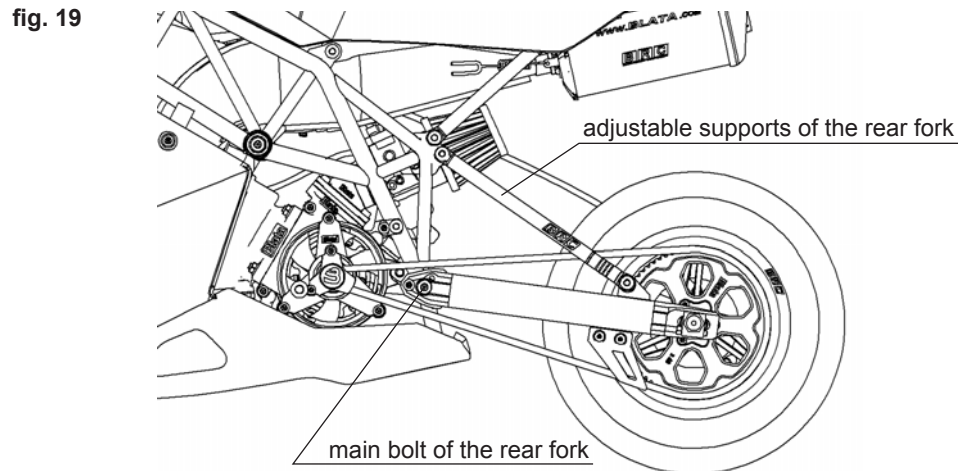

fig. 18
example of the correct positioning of
the steering plates against each other



Change of the seat height

The change is possible using the adjustable supports of the rear fork, which enable to change the height of the seat in the range of approx. 3.5 cm.



The adjustment is performed by the replacement of the spacer rollers of various lengths on the disassembled supports of the rear fork. We follow the following procedure during the replacement. Remove both the supports of the rear fork from the minibike. Totally unscrew the securing bolts from the supports. Replace the spacer rollers with others (just by sliding on). Always use the same length rollers (marked by groups) on both of the supports. Place the assembled support with the seating areas of the end pieces on to a flat pad, screw in and tighten the securing bolt. Loosen the main bolts on both sides in the front part of the rear fork. Mount the supports onto the minibike and tighten the main bolts on the rear fork.

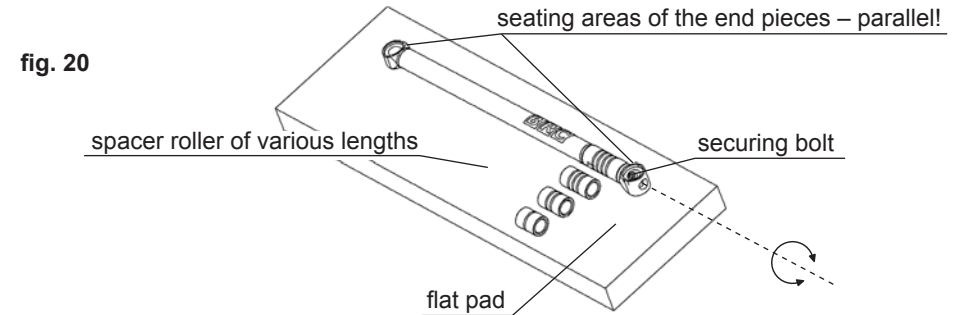

Current information on available options and components to change the height of the saddle, contact your dealer.

Change of the foot rests position

It is possible to achieve sixteen various positions of the foot rests, using the combination of 4 holes in the foot rest holders, the rotary cam and two holes in the front end piece of the rear fork. The suitable angle of the foot rest can be adjusted by turning the foot rest in the spline, through which it is attached to the foot rest holder.

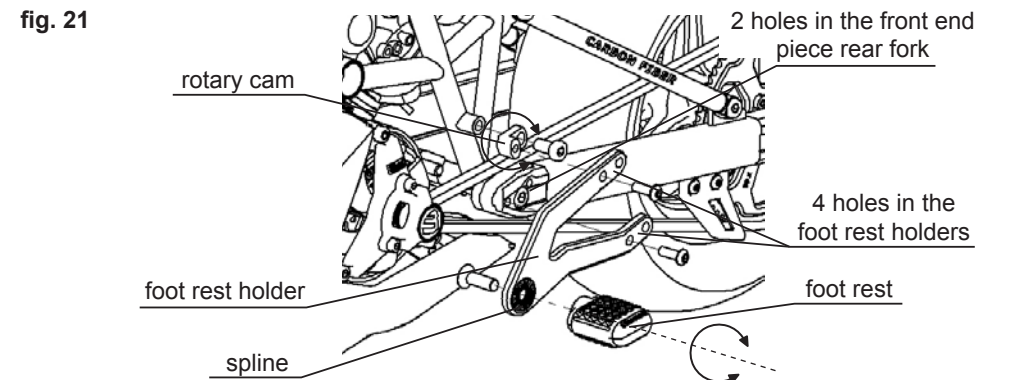

important warning regarding the change of the geometry of the chassis:
With regards to the fact that the change of the geometry of the chassis results in the change of the spatial arrangement of a significant amount of parts, always check, following the performing of the change of the geometry of the chassis, whether any collision is occurring between the parts (radiator X front wheel, cowling X brake lever, intake filter X rear wheel, cowling X front wheel, steering shock absorber X radiator etc.)

REPLACEMENT OF THE CENTRIFUGAL CLUTCH LEVERS

Loosen the chain, remove the bearing housing and take the chain off the pinion. Unscrew the 3 bolts holding the clutch housing together with the clutch basket and remove the clutch housing. Loosen the nut of the catch driver by placing a pipe between the engine block and the catch driver and then loosen the nut. Use the puller MP-1 (159.019.00) to remove the clutch set from the motor fig. 22. Unscrew the adjustment bolts of the springs and remove the lock rings from the pegs. Then replace the clutch levers with new ones. We recommend to also replace the springs. During assembly, first place on the spring with the cup onto the lever and mount them together so that the spring cup is pushed against the catch driver and place the lever onto the peg. Secure it by the lock ring and mount the adjustment bolts. Perform the basic adjustment according to chap. ADJUSTMENT OF THE CENTRIFUGAL CLUTCH page 18.

fig. 22

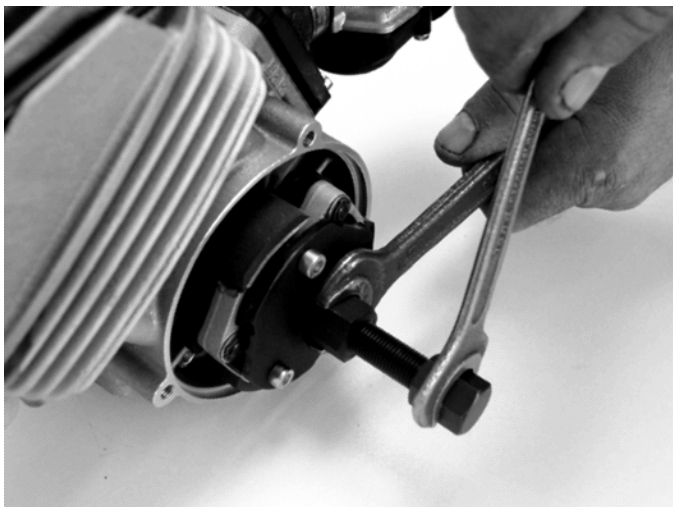

REPLACEMENT OF THE TIRE

First remove the wheel from the minibike. For the front wheel unscrew the brake disc, and for the rear wheel unscrew the brake disc and the sprocket-wheel. Release the air from the tires, preferably by unscrewing the valve out. Place the wheel on a solid pad and push the tire bead from the edge of the rim towards the middle of the rim's span area. Use one assembly lever to slip the tire bead, at the valve, across the edge of the rim and hold it there. Insert another assembly lever right beside and slip over the remaining part of the tire across the edge of the rim.

Place the second tire bead into the middle of the rim's span areas and slip it across the edge of the rim without using assembly levers. Perform the mounting in the reverse procedure. The assembling of the tire onto the rim is always started on the opposite side of the valve. Perform the air inflating of the tire according to the weight of the rider, with a maximum of 250 kPa (2.5 bars) and mount the wheel into the minibike.

REMOVAL AND MOUNTING OF THE AIR FILTER

During the removal of the filter, first loosen the screws of the strap, which is securing the rubber extension of the filter on the carburetor. This will release the filter, which is then removed and carefully washed in gasoline and smeared with oil for air filters and is mounted using reverse procedure.

ADJUSTMENT OF THE CENTRIFUGAL CLUTCH

After the first hour of riding perform the inspection of the adjustment of the clutch jaws. The clutch should engage at 8000 - 8 500 RPM according to the weight of the rider. Adjust it to the higher prescribed revolutions when the rider is of the heavier weight.

basic adjustment:

The basis for the adjustment is the length of the spring, which is measured from the seating area on the clutch lever to the spring cup fig. 23. For a new clutch (following the replacement of the clutch lining) and with a clutch drum with an inside diameter of 80 mm, set this length to 21.00 mm. During this setting the clutch starts to grab at 8000 RPM. The grabbing RPM increase as a result of the operational wear of the clutch lining and the drum. Therefore continually inspect the grabbing RPM (inspection after every ride) and loosen or possibly tighten the adjustment bolts, in order to maintain the grabbing RPM at a value of 7000 - 9000 RPM. The tightening of the adjustment bolts increases the grabbing RPM and loosening them decreases the grabbing RPM. The grabbing RPM can differ in relation to the power of the motor, the weight of the rider and the character of the track. In no case may the clutch continue to further slip after gripping (during higher RPM than the gripping RPM). This would result in a quick wearing of the clutch lining and possibly also in irreversible damage to the entire clutch. Pay attention to always set all the springs evenly, to prevent uneven wear of the clutch lining. Every time following the replacement of the clutch levers there must be performed the basic adjustment of the clutch springs to the measurement of 21.00 mm and 8000 RPM. For the setting of the gripping RPM of the centrifugal clutch, we recommend to use an RPM gauge connected to the high voltage spark plug cable.

fig. 23

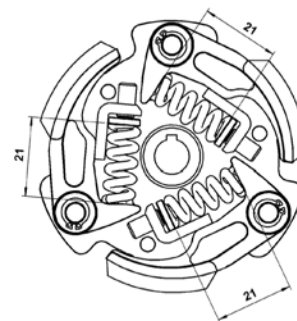

MAINTENANCE OF THE COOLING SYSTEM

1. Filling up with fluid:

Remove the top cowling. Place the minibike so that the front wheel is 30 cm higher than the rear wheel, see fig. 24. Remove the cap from the leveling reservoir and loosen the bleeding bolt M5 by 6 turns, which is located in the upper left part of the radiator. Slowly pour the cooling liquid into the leveling reservoir. The cooling fluid volume in the system is 0.5 l. Close the reservoir and the bleeding bolts. Place the minibike onto the stand and start it up, leave it running for about 1 minute. Then again place a support under the front wheel and use the bleeding screw to perform the additional bleeding. Hereby the minibike is prepared for operation.

2. Checking the cooling:

Check the amount of the fluid in the leveling reservoir before every ride! After 10 hours of operation, remove the starting cover and check the condition of the cog belt which drives the cooling fluid pump.

Important warning: turn off the engine immediately if the cooling fluid level rises in the leveling reservoir during operation! Check the drive of the cooling pump and the cooling system for leaks. After this inspection perform an air venting. The increased level of the cooling fluid is a sign of an overheated motor and the piston can get seized in the cylinder!

3. Draining the fluid:

Drain the fluid by removing the hose on the bottom part of the engine. Unscrew the cap of the leveling reservoir during the draining. Drain the fluid into a container that is prepared ahead of time and ensure the ecological liquidation of the fluid.

fig. 24

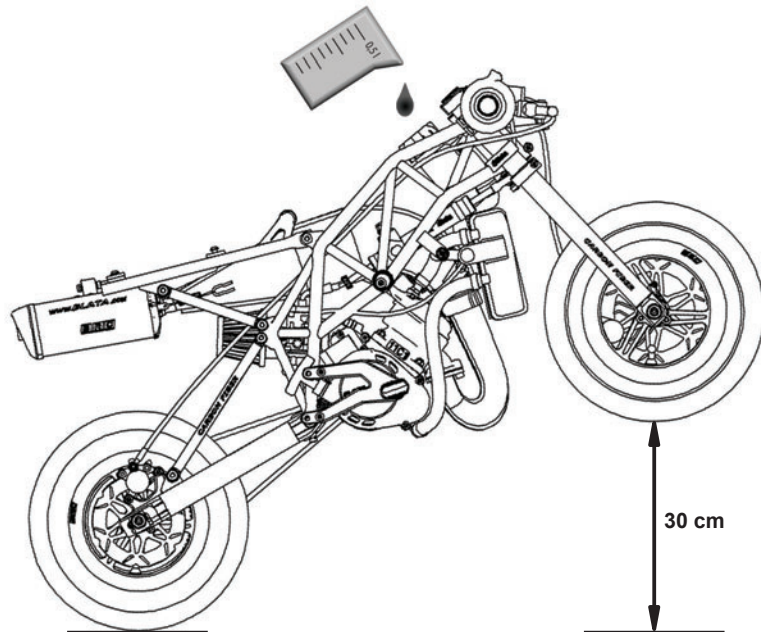

TIGHTENING TORQUES

use - MOTOR	number	fig.	pc	tightening torque (Nm)	securing
Cylinder head, water – M6	920.015.01	35, 36	5	10	
Cylinder bolt – M6	920.015.01	35, 36	4	9,5	
Intake flange – M5	914.003.01	34, 35, 36	4	5	
Starter housing – M6	914.008.01	34, 35, 36	3	10,5	
Ratchet bolt – M6	916.012.01	38	1	9	thread glue
Rotor nut – M10	920.021.01	34, 35, 36	1	25	
Starter levers' bolts – M5	916.051.01	37	2	5,5	thread glue
Coil bolts – M5	914.026.01, 914.003.01	34, 35, 36	2	5,5	
Coil holder bolt – M6	914.510.01	34, 35, 36	1	8	
Engine block bolts – M6	914.035.01	34, 35, 36	5	12	
Clutch catch driver nut – M8	920.020.01	34, 35, 36	1	22	thread glue
Clutch housing bolts – M6	914.008.01	34, 35, 36	3	10,5	
Bearing housing bolts – M6	914.001.01	39	2	10,5	
Pump axle nut – M6	920.009.01	34, 35, 36	1	8	self-locking
Membranes bolts – M3	912.010.01	41	4	0,8	thread glue
Float chamber bolts – M4	carburettor	-	2	2	
Slider cover bolts – M4	carburettor	-	2	2	
Fuel strainer cover bolt – M5	carburettor	-	1	2,5	
Pinion – M8	330.029.00	39	1	22	thread glue

used - FRAME	number		pc	tightening torque (Nm)	securing
Axle nut for front wheel – M10	920.011.01	45	1	35	self-locking
Brake disc front – M5	918.550.00	46	3	15	
Front brake holder – M6	914.035.02, 914.008.01	45	4	12,5	thread glue
Steering axle – M10	920.011.01	45	1	20	self-locking
Handlebar clamp – M6 + M5	914.003.01, 914.008.01	45	2 + 2	9,5	
Fork holders – M5	914.006.01	45	4	9	
Engine holders, head – M8	920.010.01	48	1	18,5	self-locking
Engine holders, bottom – M8	914.063.11	48	1	22	thread glue
Axle nut for rear wheel – M10	920.011.01	47	1	35	self-locking
Brake disc, rear – M5	918.550.00	47	3	15	
Sprocket-wheel – M5	914.001.01	47	3	15	
Cover for sprocket-wheel – M5	916.050.01	48	2	10	
Bolt – M3	916.179.02	53	2	2,5	
Bolts of the fairing, seat	916.005.01, 916.014.01 916.415.01	55	5	6	
Clamps for the handlebar levers – M6	brakes	-	2	7,5	
Brake levers in a clamp – M5	brakes	-	2	3,5	
Throttle handle clamp – M5	throttle grip	-	2	5	
Throttle handle cap – M4	throttle grip	-	2	2	
Reservoir holder – M6	914.080.01	50	1	6	
Front fender – M5	918.900.01	55	4	5,5	
Rear forks – M8	914.043.01	48	2	22	self-locking
Under-seat frame – M8	920.010.01	48	10	15	self-locking

COMPOSITE MATERIALS

The company Blata is the first among minibike manufacturers to bring modern composite materials. The Minibike Ultima uses carbon not only as a fashion supplement, but as a fully functional material, which exceeds the characteristics of classic metal materials. Composite materials bring not only an uncompromising lowering of weight, but also radical rigidity and excellent damping characteristics. You will immediately recognize the positive difference in the riding characteristics during the first ride on a minibike which is fitted with such components. The carbon front fork, the supports for the under-seat frame and the supports for the rear forks are manufactured using the unique patented technology of axial fiber winding.

fig. 25

CARBON FIBER

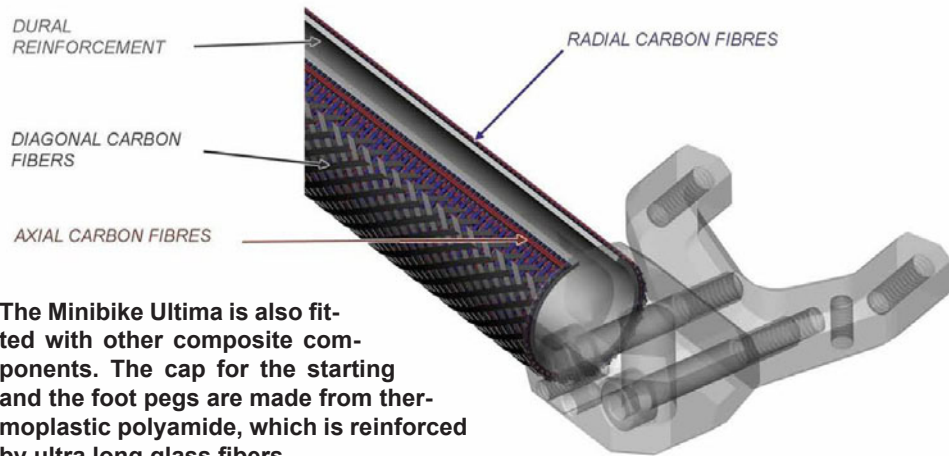

The Minibike Ultima is also fitted with other composite components. The cap for the starting and the foot pegs are made from thermoplastic polyamide, which is reinforced by ultra long glass fibers.

NOISE

The operational conditions during measuring are contained in the Report about noise measuring which is stored at the manufacturer.

Measuring is performed according to the regulation: UEM RR011 (version 2009)
 Related articles of regulation: N 86.07.07
 N 86.07.07.1
 N 86.07.07.2
 N 86.07.07.3

W50	Noise during revolutions of 8000 min ⁻¹	94,075 dB (A)
	Noise during revolutions of 9000 min ⁻¹	94,9 dB (A)
W40	Noise during revolutions of 8000 min ⁻¹	92,625 dB (A)
	Noise during revolutions of 9000 min ⁻¹	94,45 dB (A)

The prescribed noise limit according to UEM RR011 is 95 dB (A) in the range of the motor's revolutions of (8000 to 9000 min⁻¹). The prescribed noise limit was not exceeded.

DECLARATION ABOUT NOISE

The stated values are emission levels and may not resemble safe working levels. Even though there does exist a correlation between the emission levels and exposure levels, these values cannot be used to reliably determine whether further measures are necessary or not. The factors which affect the actual levels of exposure to workers include the characteristics of the working area, other sources of noise etc., for example the number of machines and other neighboring processes. The highest allowable level of exposure can also be different in individual countries. This information is to serve the user of the machine to better evaluate the danger and risk.

PUTTING OUT OF OPERATION

During a longer putting out of operation it is recommended to drain all the fuel from the tank and the carburetor. Fill up the tires to operational pressure and place the minibike on to the stand.

Furthermore, during a longer putting out of operation, unscrew the spark plug and drip several drops of engine oil into the cylinder. Then pull the starting cord several times, to form an oil film over the entire cylinder.

STORAGE

Do not leave the machine exposed to climate effects and if you intend to store it for a long period of time then ensure the preserving of all parts, which may be susceptible to oxidation. The storage must take place in a dry environment, where the temperature moves in the range of 0° to 50°C. Storage temperature -10°C to 60 °C (-10°F to 140°F), relative humidity: 20 to 80% non-condensing.

REPEAT PUTTING INTO OPERATION

Before beginning the preparation of the machine for operation, carefully perform the degreasing and un-preserving of all areas and parts which are protected against corrosion, using a suitable degreasing product designated for degreasing, which does not cause a danger of an explosion, disturbance of painted surfaces and so on.

PERMANENT PUTTING OUT OF OPERATION

In the case of disassembling the machine please refer to the manufacturer which will secure the disassembly in accordance with the valid safety regulations.

Do not drain the fluids used in the machine into the environment. First remove all the fluids used in the machine. Remove plastic and rubber materials, such as seals, hoses, cable covers, etc. These materials should be liquidated in accordance with the relevant regulations for liquidation of plastics.

Remove the engine, electrical devices and cables and hand over the copper parts for further use. It is necessary to deliver the disassembled components to the relevant centers for recycling and liquidation of waste. The machine does not contain any materials which would require special manipulation or processing during the liquidation of the machine.

TECHNICAL SERVICE

Contact your dealer in the case of any unclarity with this manual or with the maintenance and service of your minibike. The updated list of the dealers is stated on the Internet pages of the manufacturer www.BLATA.com.

HYDRAULIC BRAKES

fig. 26

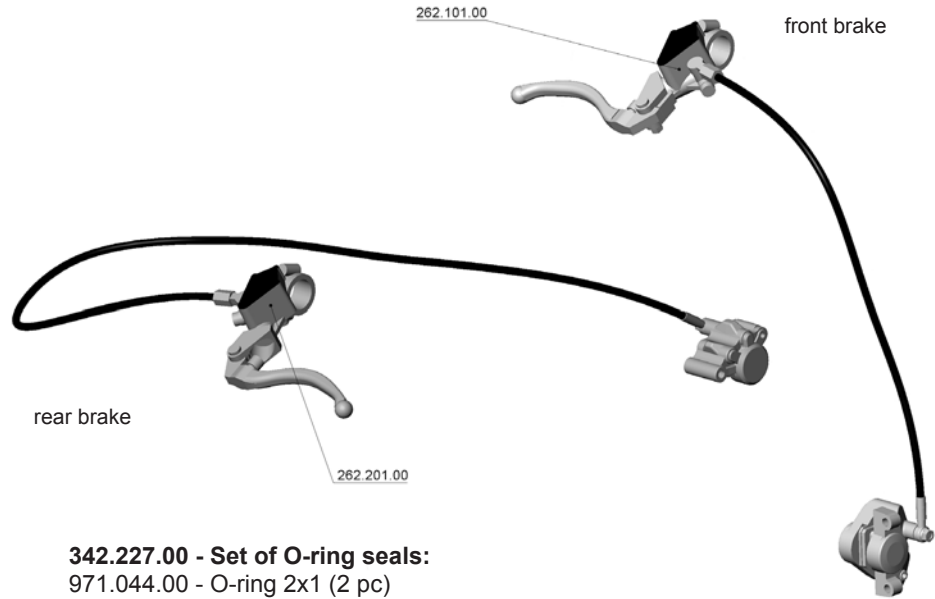

342.227.00 - Set of O-ring seals:

- 971.044.00 - O-ring 2x1 (2 pc)
- 971.049.00 - O-ring 4x1 (1 pc)
- 971.052.01 - O-ring 6x1 (4 pc)
- 971.054.01 - O-ring 8x1 (1 pc)

HOSE

fig. 27

- 262.103.00 - Rear hydraulic brake hose L=900
- 262.203.00 - Front hydraulic brake hose L=450

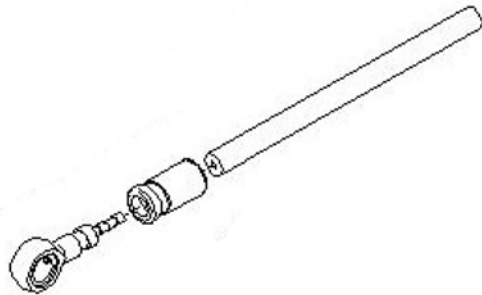

HYDRAULIC BRAKE LEVER

fig. 28

- 342.220.00 - Brake lever left (hydraulic brake)
- 342.221.00 - Brake lever right (hydraulic brake)

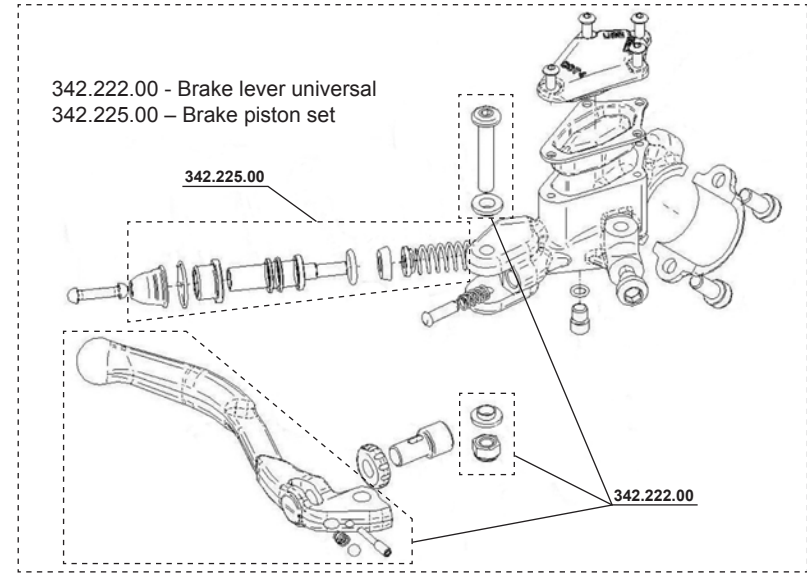

HYDRAULIC BRAKE CALIPER

fig. 29

Applies to front and rear brake

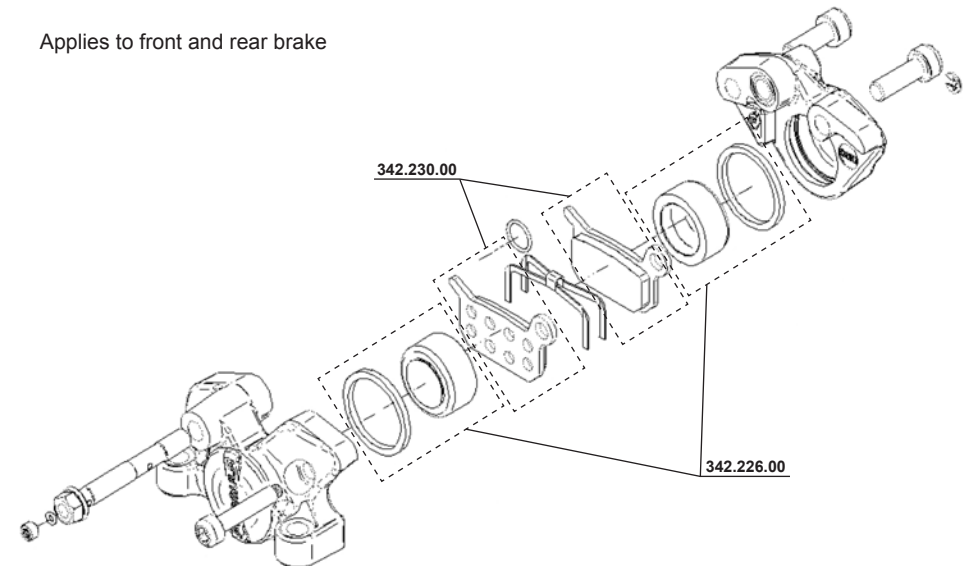

MECHANICAL FRONT BRAKE

fig. 30

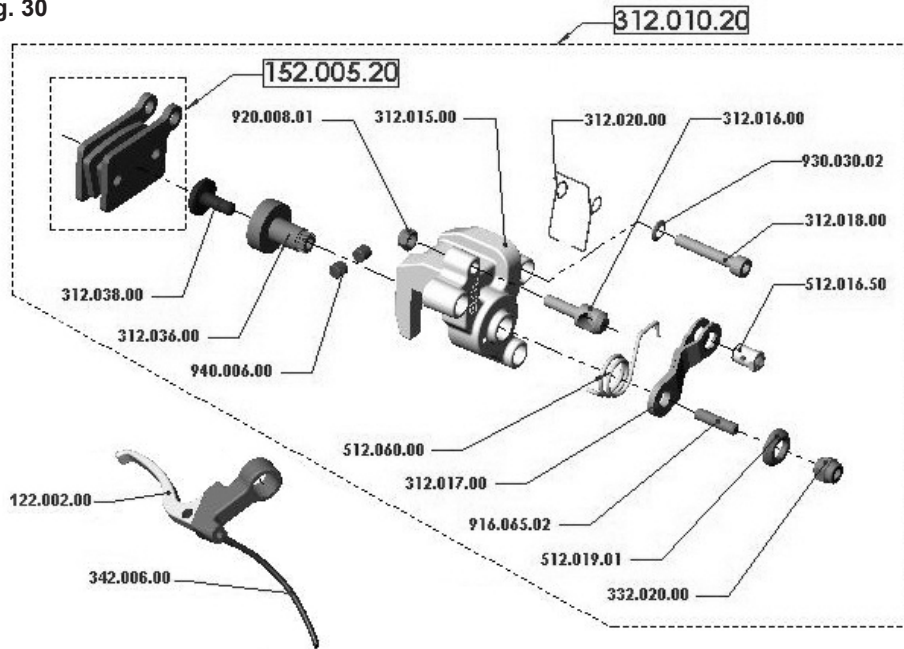

MECHANICAL REAR BRAKE

fig. 31

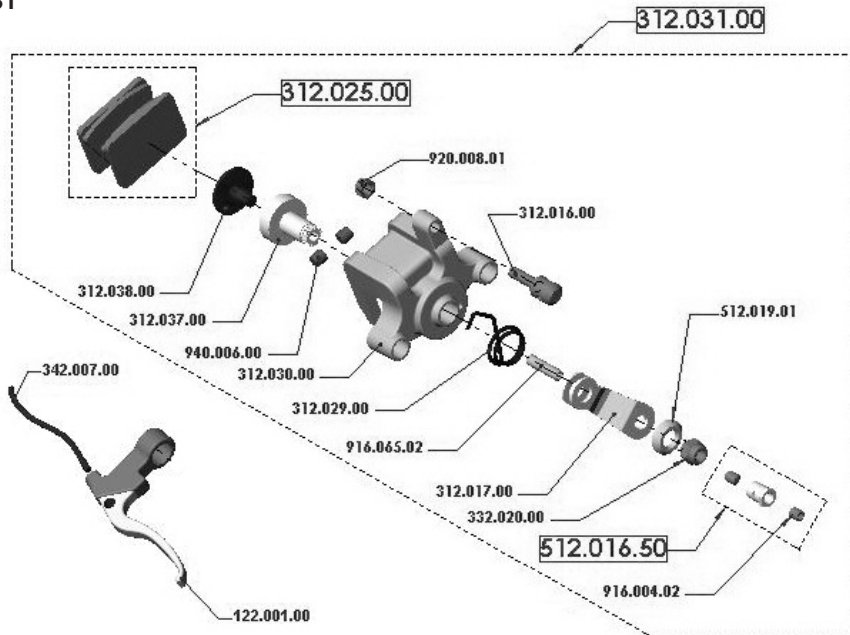

MECHANICAL BRAKES HOLDER

fig. 32

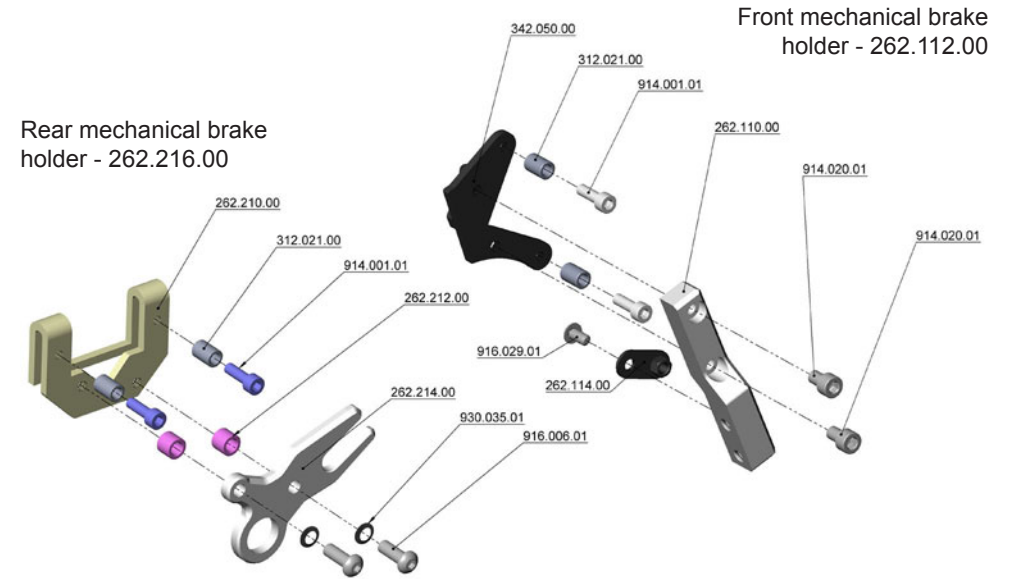

ENGINE - COMPLETE

fig. 33

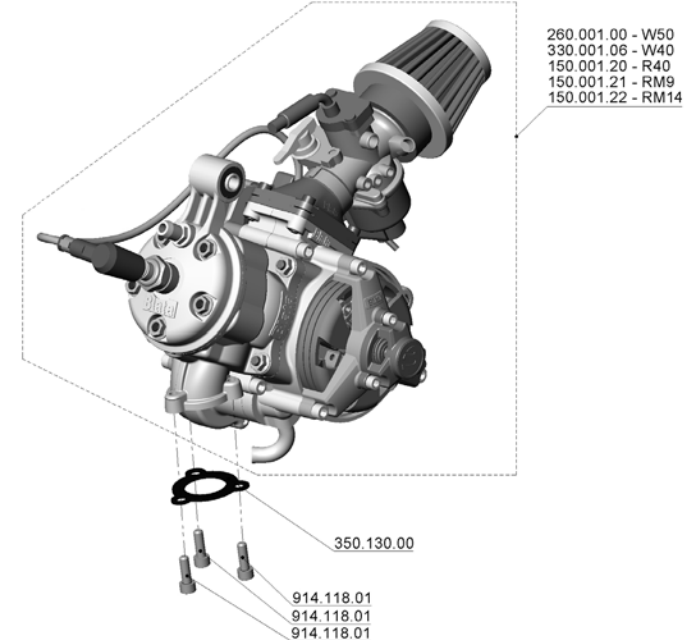

ENGINE R40, RM9, RM14

fig. 34

- 260.300.00 - Engine R40 set
- 260.400.00 - Engine RM9
- 260.500.00 - Engine RM14

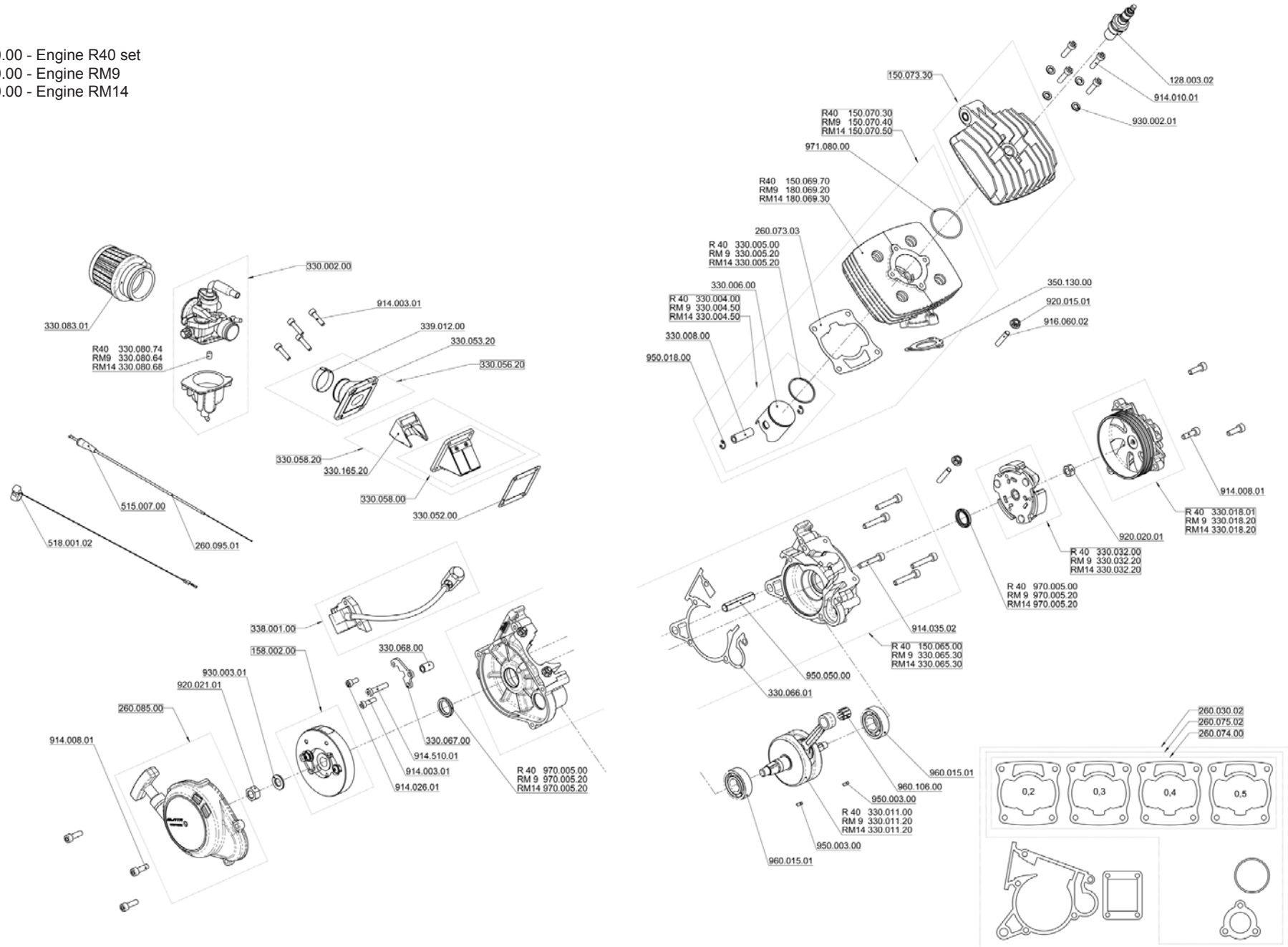

ENGINE W50

fig. 36

260.001.00 - Motor W50

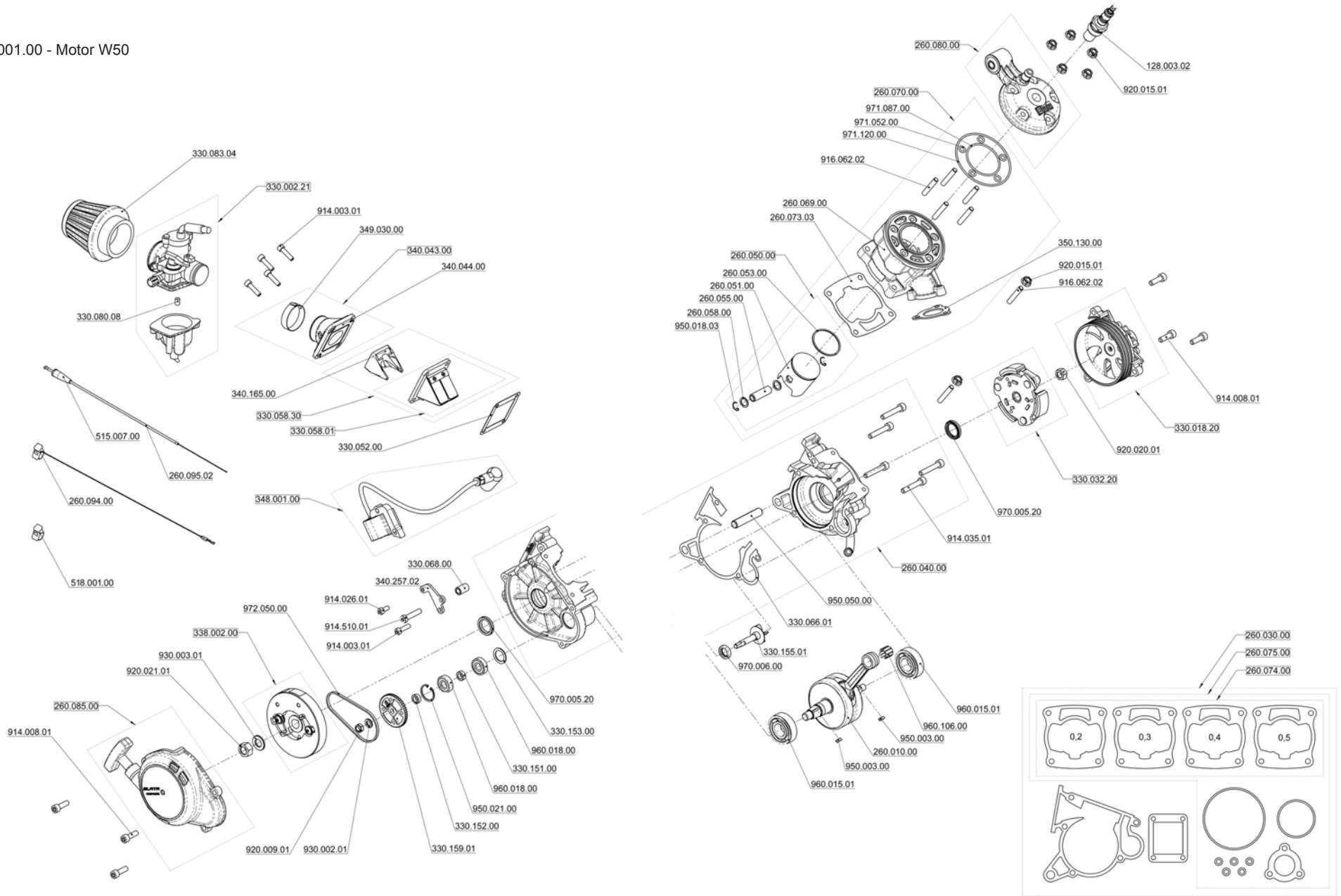

ROTOR

fig. 37

338.002.00

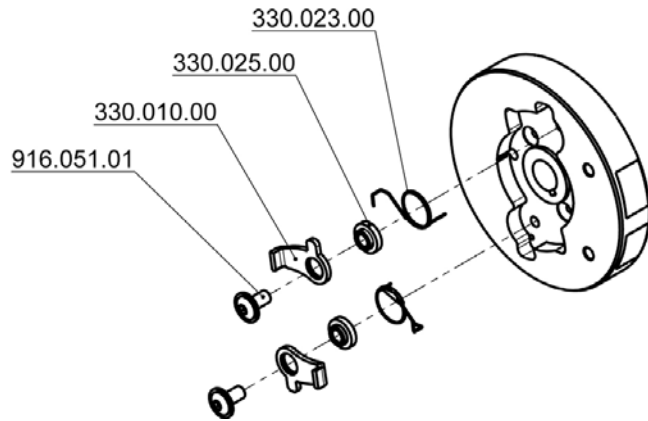

CLUTCH CASE COMPLETE

fig. 39

330.018.20 - KIT
330.018.01 - SERIE

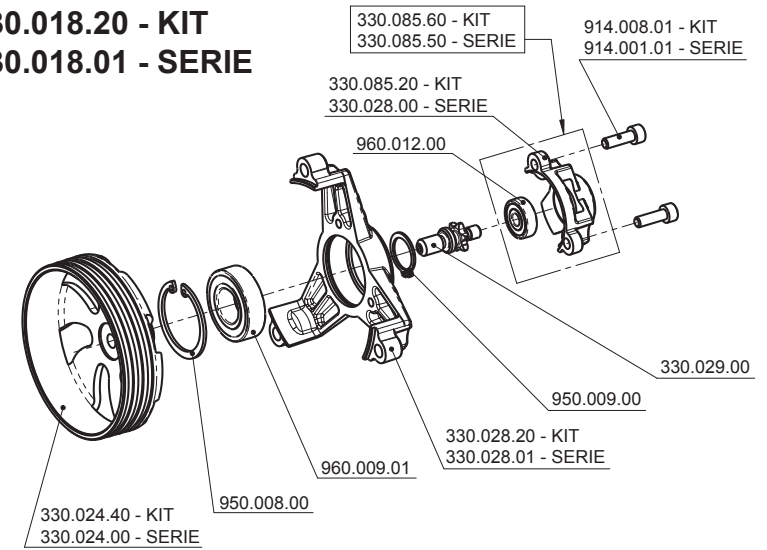

STARTER CASE COMPLETE

fig. 38

260.085.00

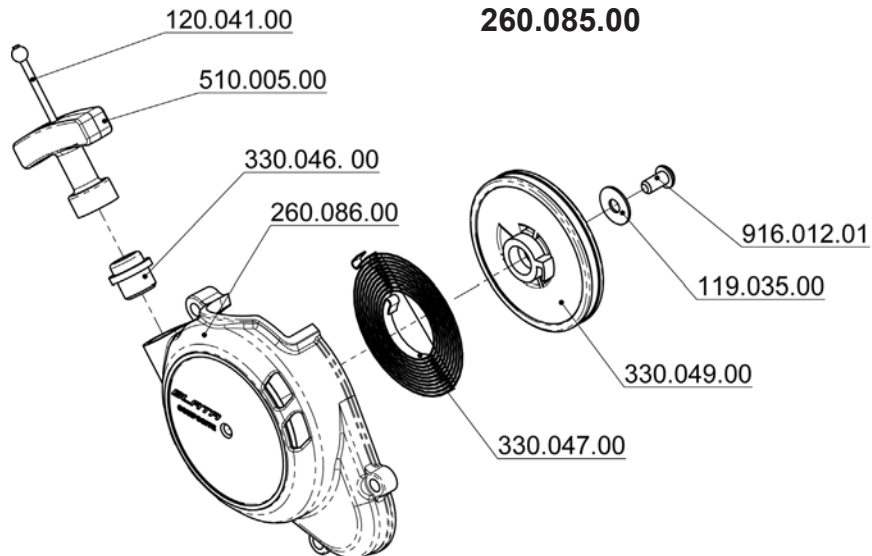

CLUTCH - COMPLETE

fig. 40

330.032.20 - KIT
330.032.00 - SERIE

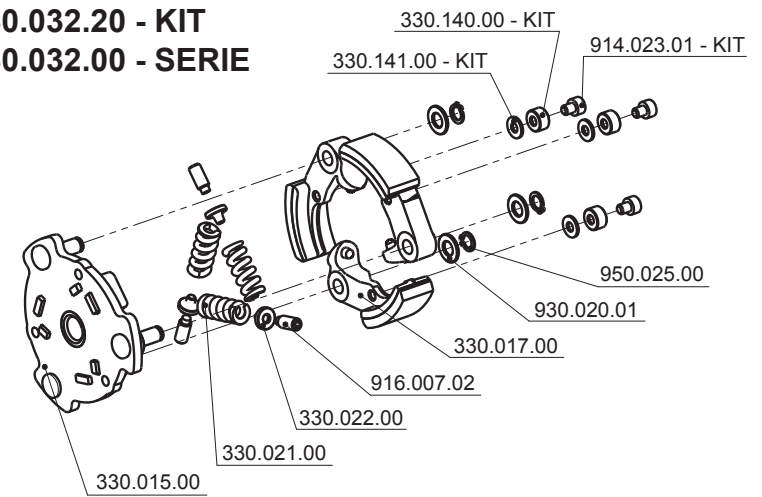

DIAPHRAGM COMPLETE

fig. 41

330.058.01

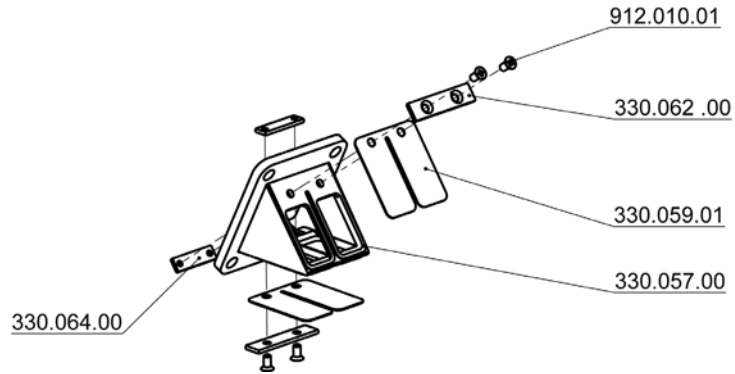

HEAD BLAST - WATER COOLING

fig. 43

330.073.42 - W40

260.080.00 - W50

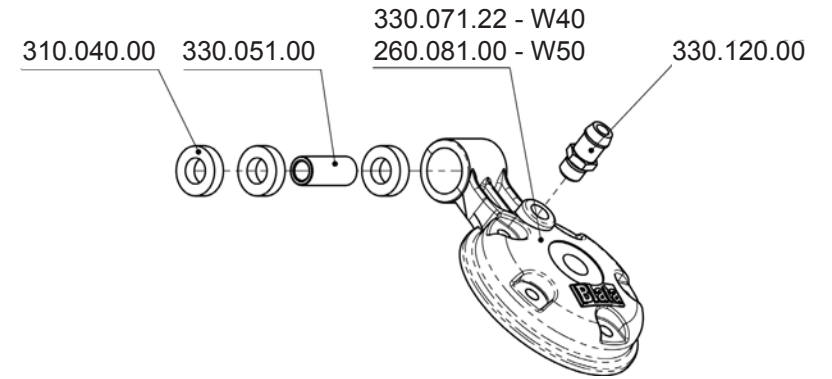

EXHAUST R40 (RM9, RM14)

fig. 42

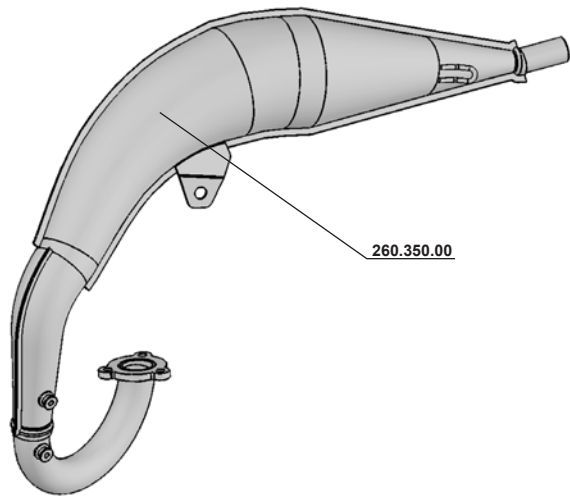

HEAD BLAST - AIR COOLING

obr. 44

150.073.30

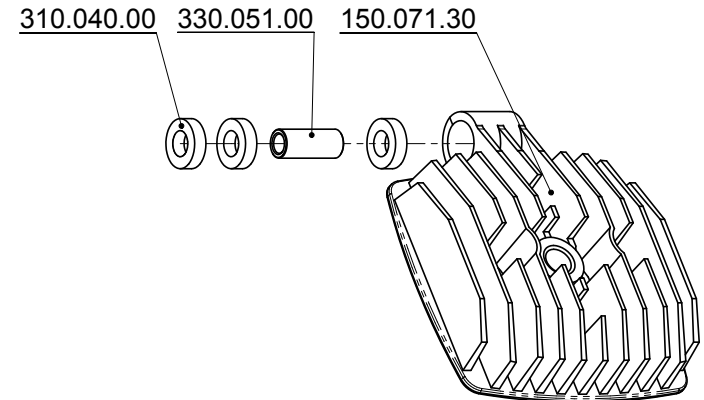

fig. 45

FRONT FORK

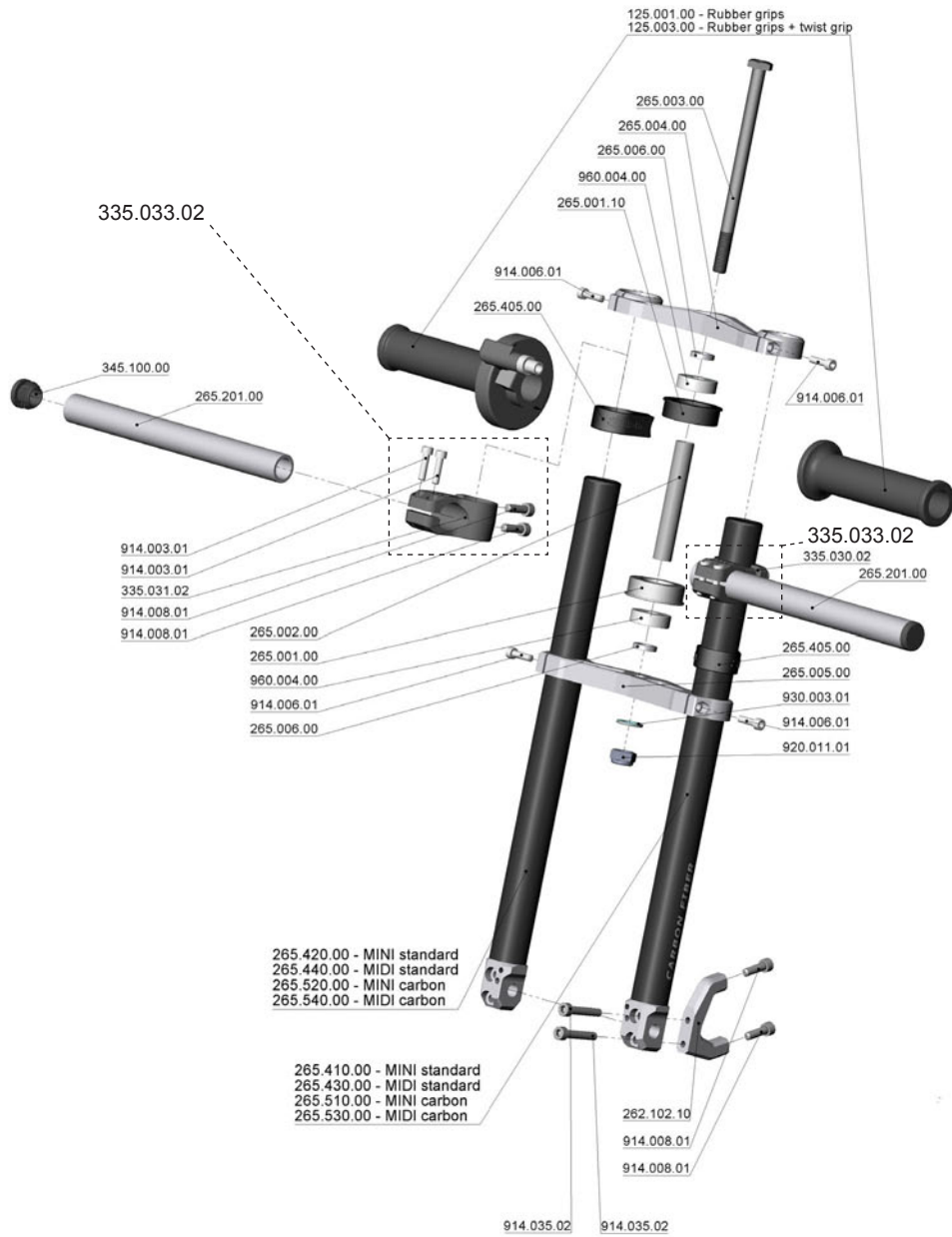

fig. 46

FRONT WHEEL

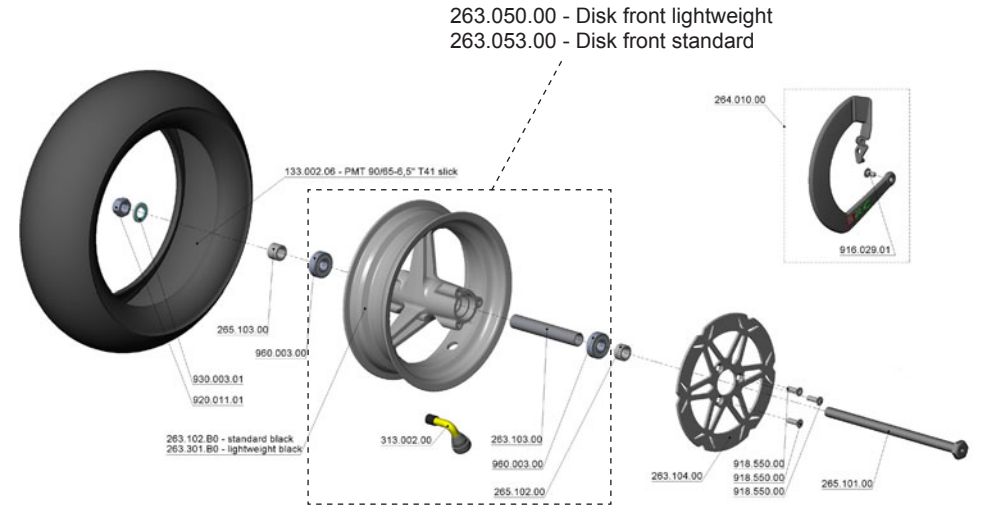
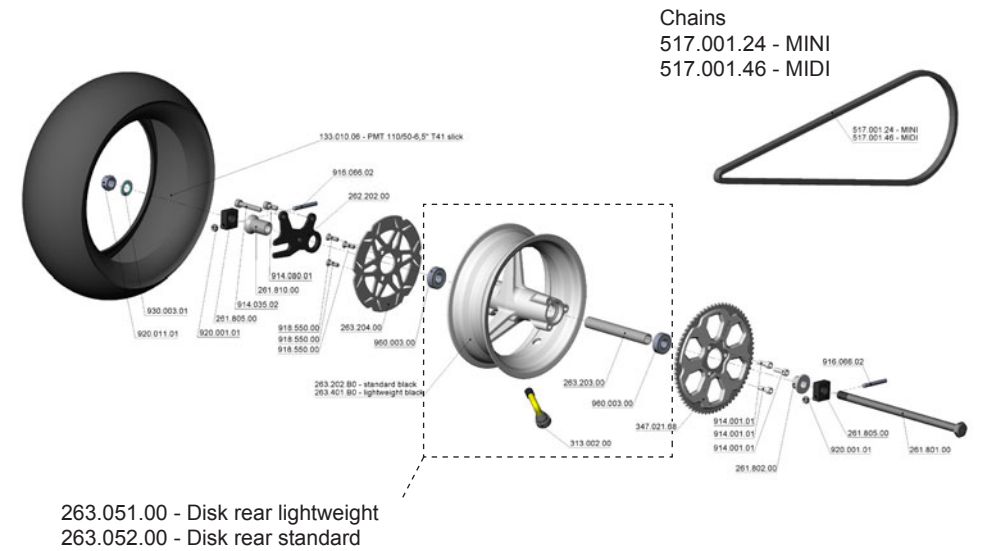

fig. 47

REAR WHEEL



EXHAUST - COMPLETE W40

fig. 51

- 260.701.01 Exhaust W40 set - standard
- 260.701.02 Exhaust W40 set - carbon cap
- 260.701.03 Exhaust W40 set - carbon body

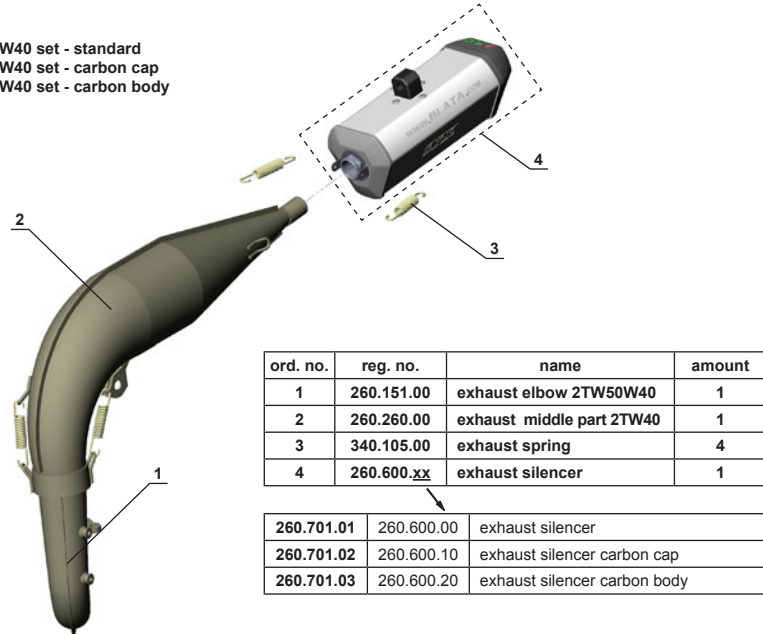

EXHAUST - COMPLETE W50

fig. 52

- 260.700.01 Exhaust W50 set - standard
- 260.700.02 Exhaust W50 set - carbon end piece
- 260.700.03 Exhaust W50 set - carbon set

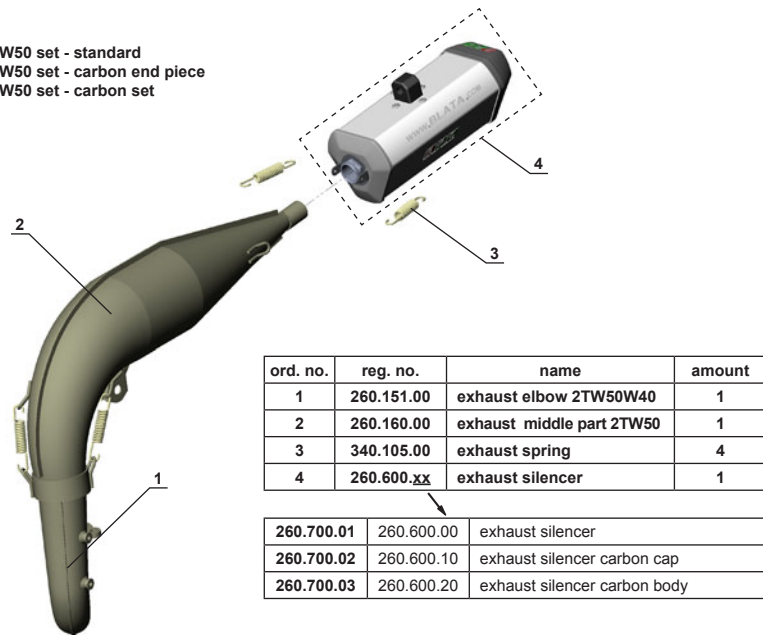

EXHAUST SILENCER

fig. 53

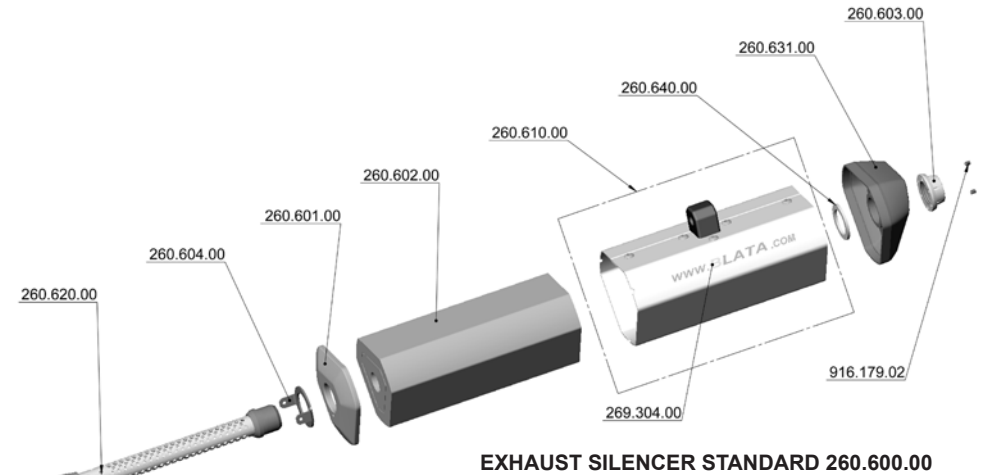

EXHAUST SILENCER STANDARD 260.600.00

name	reg. number	pc
perforated tube complete	206.620.00	1
springs plate	260.604.00	1
exhaust cap - front	260.601.00	1
silencer body complete	260.610.00	1
damping substance	260.602.00	1
distance sleeve	260.640.00	1
exhaust cap, standard	260.631.00	1
silencer nut	260.603.00	1
bolt M3 DIN 913	916.179.02	2
sticker www.biata.com size A	269.304.00	2

fig. 54

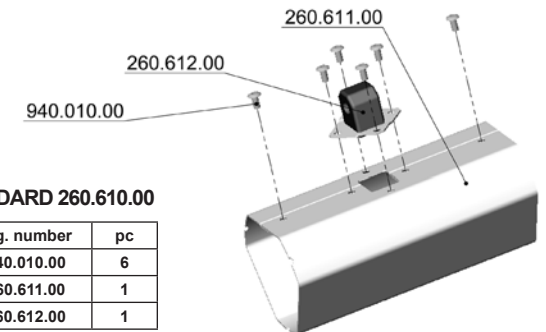

SILENCER BODY COMPLETE, STANDARD 260.610.00

name	reg. number	pc
tear-off rivet 4 x 8	940.010.00	6
silencer body standard	260.611.00	1
silencer silent block	260.612.00	1

COWLING

fig. 55

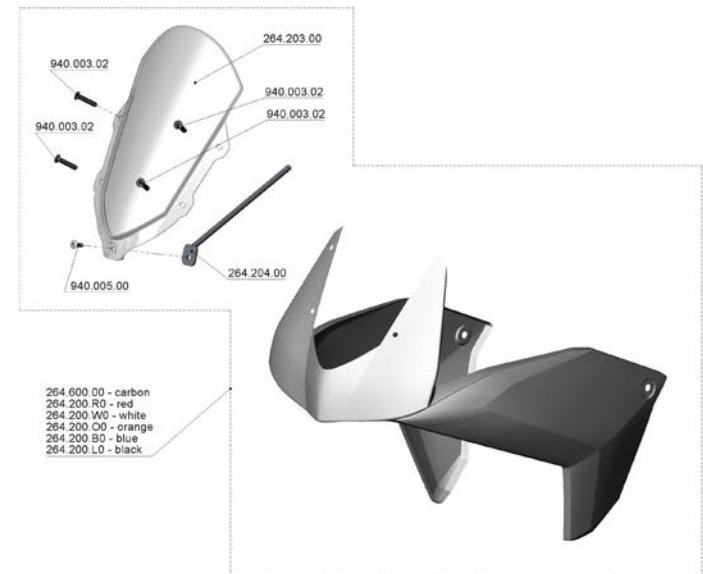
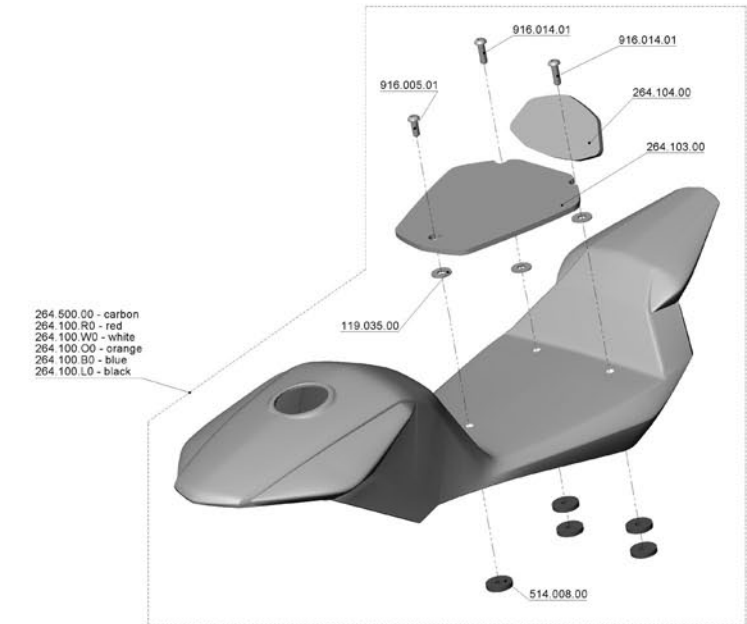
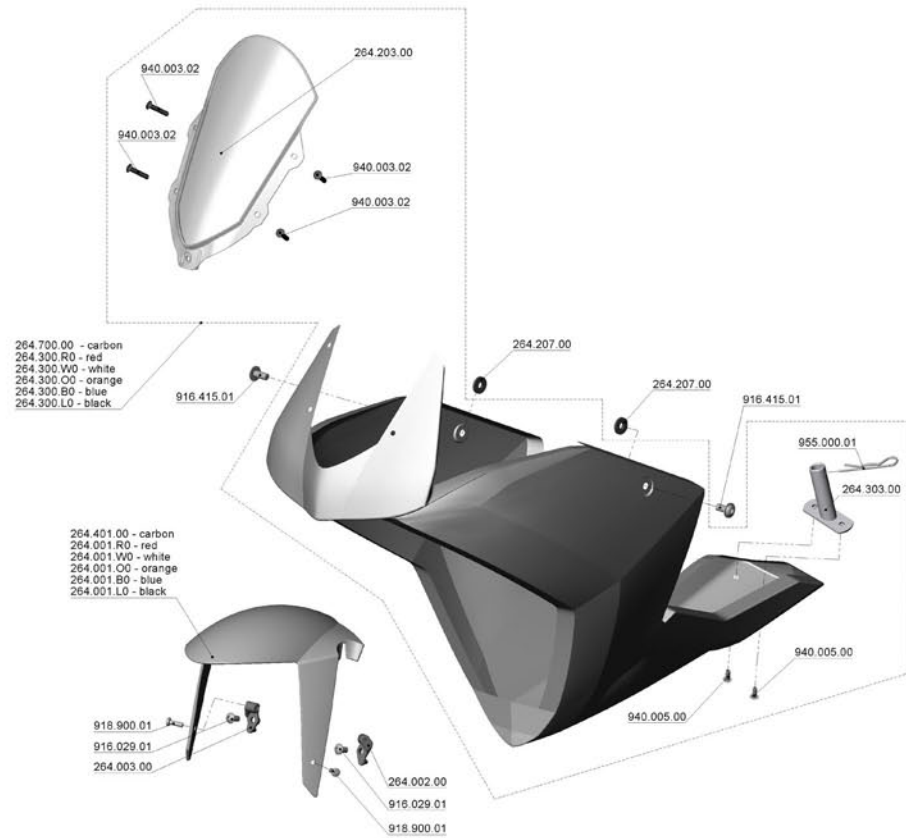

COWLING TABLE

reg. number	name	reg. number	name	amount
264.050.0B	whole - cowling complete set, blue	264.300.B0	front whole - cowling complete, blue	1
		264.100.B0	saddle - cowling complete, blue	1
		264.001.B0	front fender glass fiber - blue	1
264.050.0L	whole - cowling complete set, black	264.300.L0	front whole - cowling complete, black	1
		264.100.L0	saddle - cowling complete, black	1
		264.001.L0	front fender glass fiber, black	1
264.050.0O	whole - cowling complete set, orange	264.300.O0	front whole - cowling complete, orange	1
		264.100.O0	saddle - cowling complete, orange	1
		264.001.O1	front fender glass fiber, orange	1
264.050.0R	whole - cowling complete set, red	264.300.R0	front whole - cowling complete, red	1
		264.100.R0	saddle - cowling complete, red	1
		264.001.R0	front fender glass fiber, red	1
264.050.0W	whole - cowling complete set, white	264.300.W0	front whole - cowling complete, white	1
		264.100.W0	saddle - cowling complete, white	1
		264.001.W0	front fender glass fiber, white	1
264.051.0B	semi - cowling complete set, blue	264.200.B0	front semi - cowling, complete, blue	1
		264.100.B0	saddle - cowling complete, blue	1
		264.001.B0	front fender glass fiber, blue	1
264.051.0O	semi - cowling complete set, orange	264.200.O0	front semi - cowling, complete, orange	1
		264.100.O0	saddle - cowling complete, orange	1
		264.001.O0	front fender glass fiber, orange	1
264.051.0R	semi - cowling complete set, red	264.200.R0	front semi - cowling, complete, red	1
		264.100.R0	saddle - cowling complete, red	1
		264.001.R0	front fender glass fiber, red	1
264.051.0W	semi - cowling complete set, white	264.200.W0	front semi - cowling, complete, white	1
		264.100.W0	saddle - cowling complete, white	1
		264.001.W0	front fender glass fiber, white	1
264.060.0C	whole - cowling complete set, carbon	264.500.00	saddle - cowling complete, carbon	1
		264.700.00	front whole - cowling, complete, carbon	1
		264.401.00	front fender carbon	1
264.061.0C	semi - cowling complete set, carbon	264.500.00	saddle - cowling complete, carbon	1
		264.600.00	front semi - cowling, complete, carbon	1
		264.401.00	front fender carbon	1
264.040.01	whole - cowling complete set, unpainted	264.300.*0	front whole - cowling, complete, unpainted	1
		264.100.*0	saddle - cowling complete, unpainted	1
		264.001.*0	front fender glass fiber, unpainted	1

IDENTIFICATION INFORMATION

The following identification information will help you during service solutions and ordering spare parts.

1. Serial number – stamped on the frame head pipe
2. Manufacturing label – glued on the front fork
3. Configuration code - table

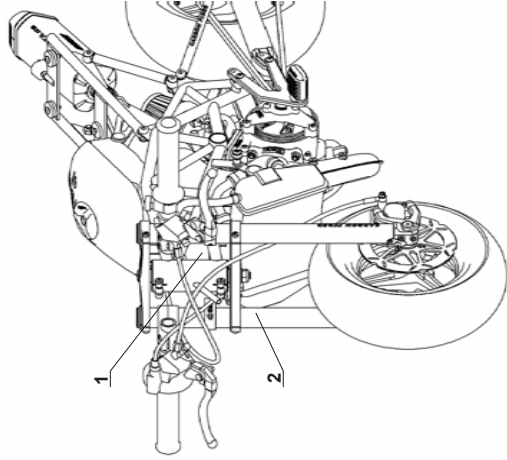

size	motor	type of fairing	frame color	material / color of fairing	front fork	rear supports	wheel disks	exhaust muffler	steering s. absorber	brakes
N / mini	A / RM9	W / whole	R / red	C / natural carbon fiber	C / carbon	C / carbon	L / light-weight	B / carbon body	Y / yes	H / hydraulic
D / midl	B / RM14	S / semi	W / white	R / red glass fiber	S / standard	S / standard	S / standard	C / carbon cap	N / no	M / mechanic
	C / R40		O / orange	W / white glass fiber		F / carbon adjustable		S / standard		
	D / W40		G / gray	O / orange glass fiber		G / standard adjustable				
	E / W50		B / blue	B / blue glass fiber						
			L / black	L / black glass fiber						

<input type="checkbox"/>	<input type="checkbox"/>	<input type="checkbox"/>	<input type="checkbox"/>	<input type="checkbox"/>	<input type="checkbox"/>	<input type="checkbox"/>	<input type="checkbox"/>	<input type="checkbox"/>	<input type="checkbox"/>	<input type="checkbox"/>
--------------------------	--------------------------	--------------------------	--------------------------	--------------------------	--------------------------	--------------------------	--------------------------	--------------------------	--------------------------	--------------------------

Thank you for the favor which you have shown to our machine BLATA ULTIMA and we wish you many true racing experiences on the track.

the company BLATA

The company BLATA reserves the right to change the technical design, text and shape of the vehicle.

Serial number: CZ

Signature of the technical inspection:

This manual serves also as a **CERTIFICATE OF WARRANTY**. When taking over the product please make sure that the correct serial number and date of sale are stated in this certificate of warranty. It is necessary to present this properly filled out certificate of warranty in the case of a claim.

The providing of the warranty does not affect the rights of the purchaser, which are bound to the purchase of the item according to special legal regulations.

Date, stamp and signature of the dealer:



**news, list of dealers, current lists of spare parts,
additional equipment offers, reports from races and other
important information can be found at:**

www.BLATA.cz

BLATA s.r.o.

**Pražská 9
678 01 Blansko
Czech Republic**

tel.: +420 516 522 111

fax: +420 516 522 100

e-mail: recepce@blata.com

contact to dealer

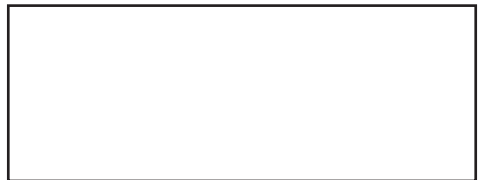

The electronic version of this brochure can be found at www.blata.cz.

COPYRIGHT © BLATA 2009